

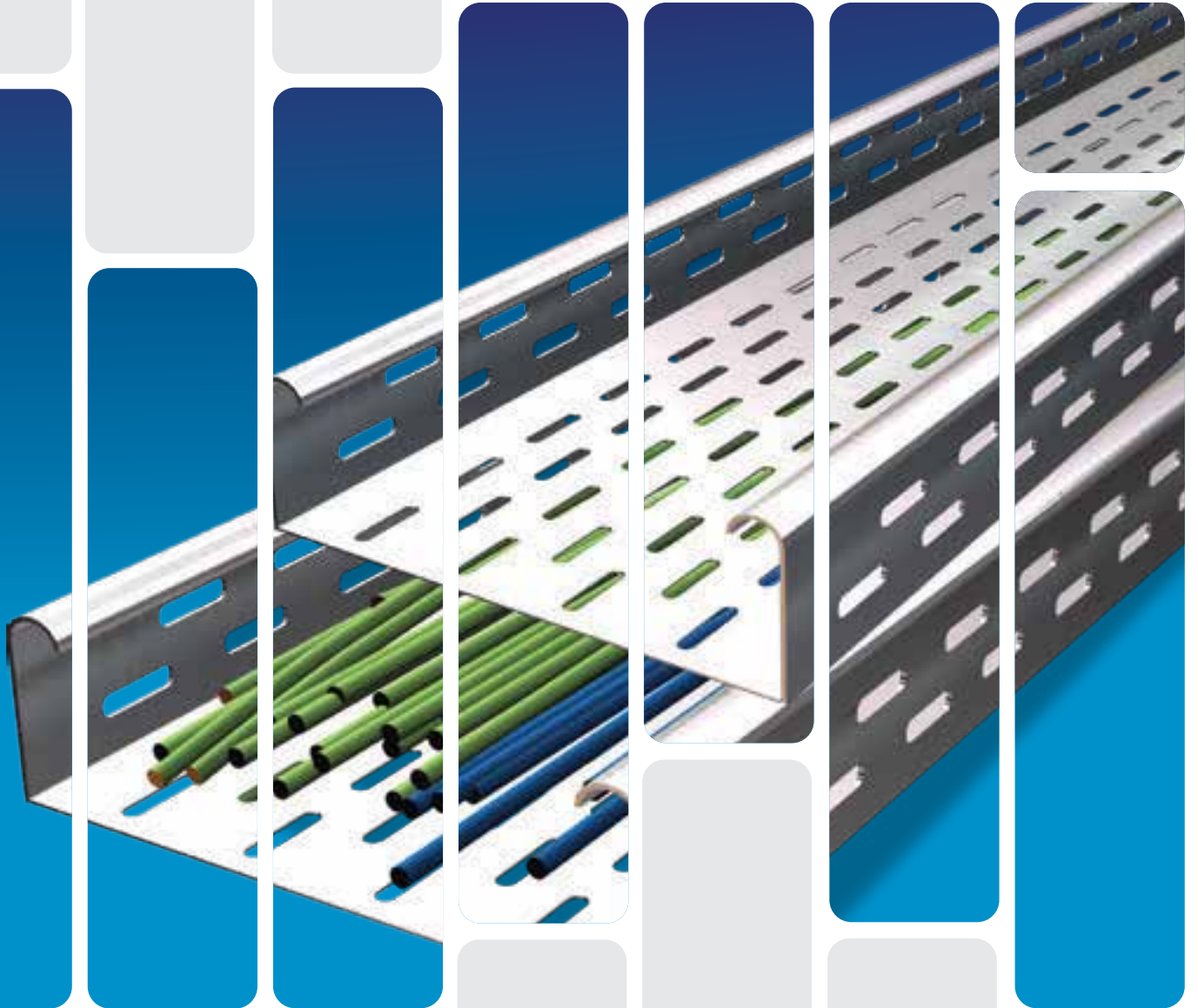

CABLE MANAGEMENT SYSTEMS CABLE TRAYS & ACCESSORIES



Powered by DEKRA



www.unitech-ikk.com
www.sfsp-ikk.com
www.ikkgroup.com



UNITECH

For Building and Construction Materials

CABLE MANAGEMENT SYSTEMS
CABLE TRAYS & ACCESSORIES

PRODUCED BY



SPECIALIZED FACTORY FOR STEEL PRODUCTS
SIGMA FACTORY FOR STEEL PRODUCTS



Cable Trays & Accessories

Index

About UNITECH	4
Cable Management System	19
Cable Trays Runs	21
Cable Tray Fittings	35
Cable Tray Accessories	48
Cable Tray Support System	57
How to Order	64
Contact Information	66



ABOUT UNITECH

Unitech Introduction

Unitech is a Saudi based Multinational Company providing building and construction solutions that is empowering the region's construction industry for the past 40+ years. We have been successfully providing solutions through mastering our main business activities: Design, Manufacture and Trade.



Design:

Provide Design & Engineering Solution to the construction sector, complying with international & local standards.



Manufacture:

Operating with Global Standards, we are widely recognized for our advanced light steel solutions and Hot-Dip Galvanization Facility.



Trade:

We are one of the region's largest Importer/Exporter of Building & Construction Materials.

Unitech is an **ISO QMS 9001:2015** certified company and is a member of the US Green Building Council. Our experienced teams and operations are present across the Middle-East North Africa regions (MENA) and Pakistan, giving us an extensive regional network that benefits our clients and partners. We are also present in Europe via our design and engineering office in Stuttgart.

For more information, please visit: www.unitech-ikk.com

Mission & Vision

Mission

We have the conviction to be the leader in building & construction industry through:

- Providing excellence in services with passionate & educated sales force
- Strengthen culture through unified sense of purpose
- Innovative product range which is customer centric
- Reputable and quality service company
- Attracting, engaging and retaining talent

Vision

To be the Customer's First Choice...

Our Strategy

Unitech's strategy continues to focus on accelerating its business throughout the region, to service the construction sector via superior products & solutions, backed up by a group of highly experienced people in the field. Unitech also aims to enhance its geographical presence in its areas of interest and where opportunities exist.

We combine a deep understanding of building and construction materials markets with a successful history of upgrading our products and developing our processes.

We have the qualified employees, the know-how and the products to service major construction projects, medium sized to mega projects taking in care our positive contribution to our societies.

We thrive towards excellence by acknowledging:



Customer Satisfaction



Partner and Supplier Relations



Employee Retention



Positive Influence on Society and Environment

Our Employees

We are a company that prides itself on its 'family' culture and we seek out high-caliber people. We are a company that has, at its core, a team philosophy that is clearly apparent each and every day - there is a real sense of being there for one another.

We believe in nurturing the skills of our team members and providing growing levels of responsibility. Our people bring unique skills, energy, expertise, experience and perspectives to our workforce.

Unitech's family of employees consists of experienced, well-motivated and dedicated team of engineers, technicians, sales executives and management staff. This team is committed to serve our customers, with the best solutions available in the market.

Our Journey

40+ Years of Excellence

Since 1979, having been set to become an independent company under the framework developed by Sheikh Isam Kabbani, Unitech started its journey of success with confidence and enthusiasm, hard work and care to detail and a commitment to become the best within its industry.

Its dedicated people could only imagine what the future could bring to this newly established entity. Unitech's journey of success has been marked with outstanding achievements and superior accomplishments. Year by year, Unitech has been acknowledged as the "First Choice for Building & Construction Material" by major construction consultants in the region, governmental authorities, well-known contracting and project development corporations.

We have obtained invaluable knowledge about the construction industry in general, providing specialized solutions to construction projects throughout MENA region. From a couple of outlets in Saudi Arabia, Unitech today is present all over the Kingdom and in several countries throughout the region providing its products and solution to various locations worldwide.



Est. 1979

THE BEGINNING

Unitech was established in the Western Region of KSA as a Sales Company selling basic construction material.

During the same year, another branch was established in the heart of the kingdoms capital, Riyadh.



1980 to 1989

AGE OF GREAT RISK

Unitech Dammam was open for business in the oil-rich eastern coast of Saudi Arabia.

Within these 10 years the idea of in-house manufacturing facility was born and Specialized Factory for Steel Products (SFSP) was established in Riyadh.



1990 to 1999

AGE OF GROWTH

Branches of Unitech were established in Makkah, Madina, Khamis Mushayt and Jubail.

The need to increase its range of products and the necessity to have production lines for mass production lead to the decision to move the SFSP Factory from Riyadh to Jeddah.

Pioneering Construction Since 1979

We are constantly evolving in order to become more flexible in our operations, more sustainable in our societies, and more innovative in conducting our business.

By delivering superior products tailored to the specific construction needs, ambitious solutions, and an outstanding customer service, we serve today's needs through developing tomorrow's markets.

Helping construction projects experience success is what fueled its days. Unitech is keen to continue offering superior products, a wide spectrum of solutions, governed by our top-notch management style.

Such aspirations require trust in our responsibilities. Our Responsibilities for the future and with this in mind we continue to target excellence with committed efforts.



2000 to 2015

AGE OF CONSTRUCTION BOOM

Qassim, Hofuf and Yanbu Branches were inaugurated in KSA and branches outside KSA were established in UAE, Egypt, Lebanon, Oman, Jordan and Germany in order to facilitate the construction boom in the Middle East.

During this period SFSP state of the art facilities were launched in DIC UAE and Unitech thrived, marking some of the best years in business.



2016 to 2019

AGE OF GREAT CHANGE

This period, marked the age of great change in order to align with the economic shift in the GCC and the world in general.

Company wide right sizing initiatives were taken especially in KSA to align with the kingdom's ambitious vision 2030 and during this period the upgraded SFSP state of the art facilities were launched in JIC 3 KSA.



2020 & Beyond

NEW FRONTIER

This period marks the expansion of Unitech into the South and Central Asian territories. We aim to cater these markets and play an active role in these countries development.

During 2020, Unitech Pakistan was officially inaugurated and marked the entrance of Unitech into Asian Market.

Our Manufacturing Arm SFSP

SFSP is a leading manufacturer and fabricator of light steel construction products in the region, servicing the construction sector through its state of the art facilities which are spread all over the MENA region. Products of SFSP are manufactured from quality raw material according to the relevant international standards to meet all kinds of construction projects requirements, such as MEP, façade, blockwork & waste management systems.

Commitment to Quality

Our commitment to quality is clearly revealed in the way we do our business; our processes, our close interaction with our clients as well as the strict product inspection procedures. To achieve this, we have implemented quality systems & processes that are continually being improved to satisfy our customer's needs.

Product Development

Product development process is substantial to the success of our business. We leverage all resources to provide up-to-date reliable products, environmentally friendly, durable to withstand the toughest weather conditions. Our engineers are constantly testing the products, seeking to present a combination of performance and quality across all our product ranges.

For more information, please visit:
www.sfsp-ikk.com

Value Chain

Our value chain starts up with the quality of the raw materials and ends up in client satisfaction. Our business practices backed up by all technologically essential business elements are supported by an efficient logistics, warehousing and delivery system that maintains a valuable supply chain for products.

The value chain is integrated in our business module, giving us strength and preserving our good reputation gained through the past 4 decades.

Engineering Specialty

Our products development engineers integrate their vast knowledge to provide the perfect solution to projects within the required specifications and time-frame.

The products development department maintains highly skilled calibers with a dedication towards efficient and reliable solutions even in the most complicated cases where delicacy and skillful approaches are indispensable.

Design and Product Safety

Our design and engineering office in Stuttgart ensures our products comply with relevant European and international standards of fabrication, taking into attention the safety factors which govern the public safety of projects.

Sustainability and Responsibility

We are constantly working hard to reduce our environmental footprints while maintaining the high quality and safety standards. We have set our targets to become three times more efficient in the next 10 years. Our responsibility towards our stakeholders is valued through our positive contributions towards our colleagues, our business partners and our communities as well.

Our Design Office



UNITECH DEUTSCHLAND is a "Design & Engineering" Office. Unitech Germany support Unitech & SFSP operations through well-informed cadre of engineers. They help our customers from conception to the completion by delivering design, engineering and project management services.

Thanks to our multidisciplinary team in Unitech Germany and their expertise, we assist you in your ambition to develop your innovation, your engineering and your organization. Our goal is to serve our clients through these elements:

- Excellent in engineering ideas and solutions
- High quality in performance
- Firmness on meeting deadlines

SFSP Certifications

ISO 9001 : 2015 (Quality Management Systems)

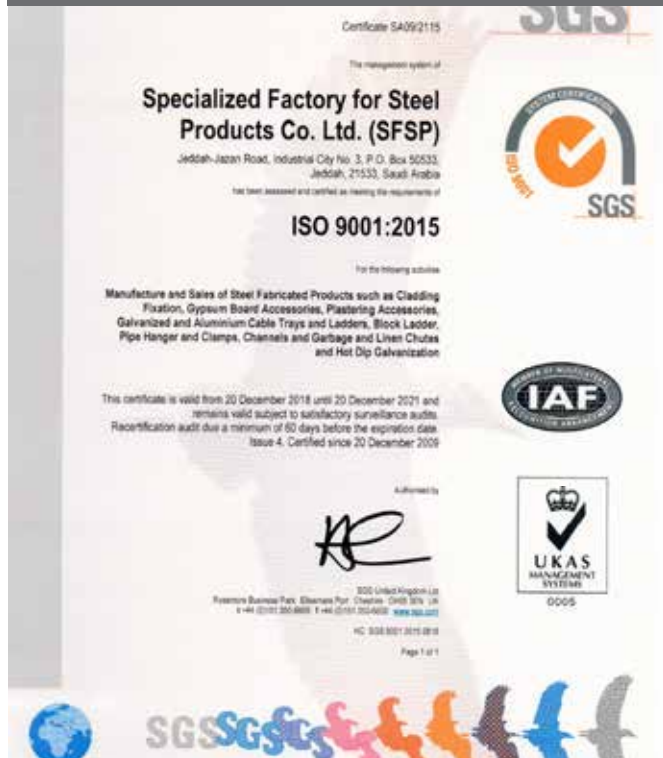

14001 : 2015 (Environmental Management System)

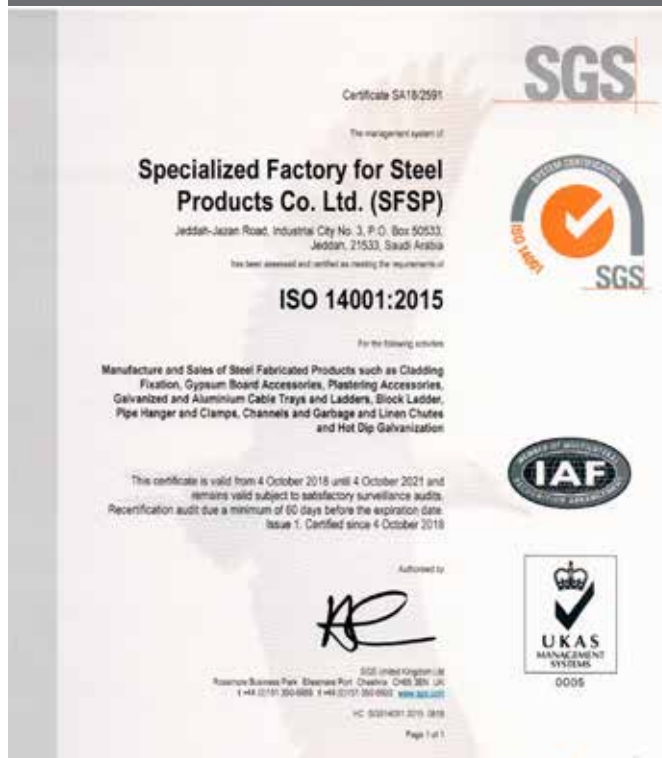

ISO 45001 : 2018 (Occupational Health & Safety)

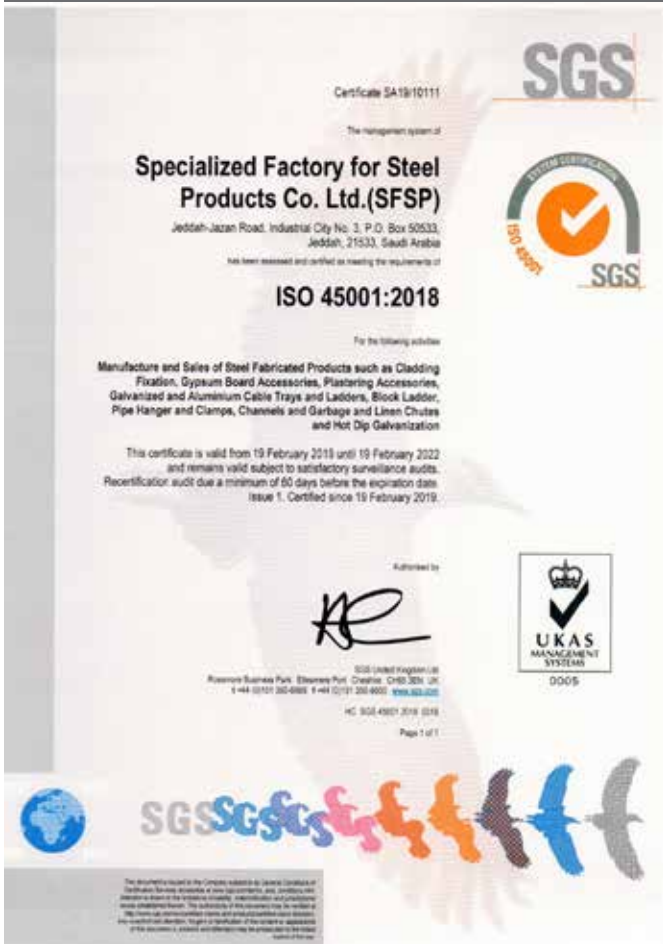

STD 096 (Q-Mark Certificate)





CERTIFICATE OF REGISTRATION

This is to certify that

Sigma Factory for Steel Products
P.O. Box 37991
Dubai Industrial City
Dubai
United Arab Emirates

Meets the requirements of the Exova BM TRADA Q-Mark International Fire Door Manufacture scheme to **STD 096 - Issue 3 - 01/12/2015** which only operates in Bahrain, Egypt, Iraq, Jordan, Kuwait, Lebanon, Libya, Oman, Qatar, Saudi Arabia and The United Arab Emirates for the products on the attached schedule



Karen Prendergast
Senior Director - Certification
Exova BM TRADA

Certificate Number
476

Date of Initial Certification
16 June 2014

Date of last issue
13 October 2017

Date of Expiry
15 June 2020

Exova (UK) Ltd, (T/A Exova BM TRADA), Chiltern House, Stocking Lane, High Wycombe, Buckinghamshire, HP14 4JD, UK
Registered Office: Exova (UK) Ltd, Lochend Industrial Estate, Newbridge, Midlothian EH28 9PL, United Kingdom. Reg No. SC070429.

This certificate remains the property of Exova (UK) Ltd. This certificate and all copies or reproductions of the certificate shall be returned to Exova (UK) Ltd or destroyed if requested. Further clarification regarding the scope of this certificate and verification of the certificate is available through Exova BM TRADA or at the above address or at www.exovabmtrada.com

The use of the UKAS accreditation mark indicates accreditation in respect of those activities covered by the accreditation certificate 012

Multiple clients - The scope of certification shown above includes the participating sites shown on the registration schedule

Page 1 of 2

ISO 9001 : 2015
(Quality Management System)



Certificate of Registration

This is to certify that the Management System of:

Sigma Factory for Steel Products

P.O. Box 37991, Saih Suhaib - 3, 4 Round About, Dubai Industrial City
Dubai, United Arab Emirates

has been approved by Alcumus ISOQAR and is compliant with the requirements of:
ISO 9001:2015



Certificate Number: 22244-Q15-001
Initial Registration Date: 23 February 2015
Previous Expiry Date: 22 February 2021
Recertification Date: 30 November 2020
Re-issue Date: 01 December 2022
Current Expiry Date: 22 February 2024

Scope of Registration:

Trading and Manufacturing of all kinds of Steel Related Construction Materials

Signed:
Alyn Franklin, Chief Executive Officer
(on behalf of Alcumus ISOQAR)

This certificate will remain current subject to the company maintaining its system to the required standard. This will be monitored regularly by Alcumus ISOQAR. Further clarification regarding the scope of this certificate and the applicability of the relevant standards' requirement may be obtained by consulting Alcumus ISOQAR.

Alcumus ISOQAR Limited, Alcumus Certification, Cobra Court, 1 Blackmore Road, Stretford, Manchester M32 0QY
T: 0151 865 3699 F: 0161 865 3685 E: iso@alcumusgroup.com W: www.alcumusgroup.com/isoqar
This certificate is the property of Alcumus ISOQAR and must be returned on request.

ISO 14001 : 2015
(Environmental Management System)



Certificate of Registration

This is to certify that the Management System of:

Sigma Factory for Steel Products

P.O. Box 37991, Saih Suhaib - 3, 4 Round About, Dubai Industrial City
Dubai, United Arab Emirates

has been approved by Alcumus ISOQAR and is compliant with the requirements of:
ISO 14001:2015



Certificate Number: 22244-E15-001
Initial Registration Date: 22 September 2015
Previous Expiry Date: 21 September 2021
Recertification Date: 11-12 July 2021
Re-issue Date: 01 December 2022
Current Expiry Date: 21 September 2024

Scope of Registration:

Trading and Manufacturing of all kinds of Steel Related Construction Materials

Signed:
Alyn Franklin, Chief Executive Officer
(on behalf of Alcumus ISOQAR)

This certificate will remain current subject to the company maintaining its system to the required standard. This will be monitored regularly by Alcumus ISOQAR. Further clarification regarding the scope of this certificate and the applicability of the relevant standards' requirement may be obtained by consulting Alcumus ISOQAR.

BS EN 61537:2007 (KEMA - KEUR Certified For Cable Management Products)

CERTIFICATE

Issued to:
Applicant:
Isam Kabbani Trading Est. (Unitech)
Rashidiya
Dubai, United Arab Emirates

Manufacturer/Licensee:
Sigma Factory for Steel Products (SFSP)
Saih Shuaib 3, AR/A, Dubai Industrial City,
Dubai, United Arab Emirates

Product : Cable management system
Trade name : SFSP
Types : IE-CT-X-10, IE-CT-X-12, IE-CT-X-15, IE-CT-X-20

The product and any acceptable variation thereto is specified in the Annex to this certificate and the documents therein referred to.

DEKRA hereby declares that the above-mentioned product has been certified on the basis of:
- a type test according to the standard IEC 61537:2006 and EN 61537:2007
- an inspection of the production location according to CENELEC Operational Document CIG 021
- a certification agreement with the number 2156954

DEKRA hereby grants the right to use the KEMA-KEUR certification mark.

The KEMA-KEUR certification mark may be applied to the product as specified in this certificate for the duration of the KEMA-KEUR certification agreement and under the conditions of the KEMA-KEUR certification agreement.

This certificate is issued on: 20 January, 2014 and expires upon withdrawal of one of the above mentioned standards.

Certificate number: 2156954.01

DEKRA Certification B.V.

drs. G. J. Zoetbrood
Managing Director

H.R.M. Barends
Certification Manager

© Integral publication of this certificate is allowed

ACCREDITED BY THE
DUTCH ACCREDITATION
COUNCIL



DEKRA Certification B.V. Meander 1051, 6825 MJ Arnhem P.O. Box 5185, 6802 ED Arnhem The Netherlands
T +31 88 96 83000 F +31 88 96 83100 www.dekra-certification.com Registered Arnhem 09085396

UL Certification* (Cable Trays)

CERTIFICATE OF COMPLIANCE

Certificate Number 20160816-E483358
Report Reference E483358-20160816
Issue Date 2016-AUGUST-16

Issued to: Sigma Factory for Steel Products
 Saih Shuaib 3, 4 R/A Dubai Industrial City
 Opposite DEWA Substation
 Dubai UNITED ARAB EMIRATES

This is to certify that representative samples of CABLE TRAYS
 Steel Channel Cable Tray, Ventilated, Heavy Duty (HCT),
 Very Heavy Duty (VCT) cable trays.

Have been investigated by UL in accordance with the Standard(s) indicated on this Certificate.

Standard(s) for Safety: ANSI/NFPA 70, "National Electrical Code" (NEC)
Additional Information: See the ULC Online Certification Directory at www.ulc.ca for additional information

Only those products bearing the ULC Listing Mark should be considered as being covered by ULC's Listing and Follow-Up Service.

The ULC Listing Mark generally includes the following elements: the symbol ULC in a circle, with the word "LISTED"; a control number (may be alphanumeric) assigned by ULC, and the product category name (product Identifier) as indicated in the appropriate ULC Directory.

To confirm the status, validate the above information via the online directory.

Look for the ULC Listing Mark on the product.

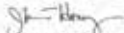
 Joseph Henry, General Manager, Director of Sales - Canada
 UNDERWRITERS LABORATORIES OF CANADA INC.

Any information and documentation involving ULC Mark services are confidential and intended only for the recipient. Please contact ULC Customer Service Dept.

Page 1 of 1

UL Certification* (Chute Type Fire Doors)

CERTIFICATE OF COMPLIANCE

Certificate Number 20170811-R38825
Report Reference R38825-20170811
Issue Date 2017-AUGUST-11

Issued to: Sigma Factory for Steel Products
 Saih Shuaib 3, 4 R/A Dubai Industrial City
 Opposite DEWA Substation
 Dubai UNITED ARAB EMIRATES

This is to certify that representative samples of CHUTE-TYPE FIRE DOORS
 Chute-type fire door and frame assembly of the insulated type, rated up to and including 2 hr, 450°F Temperature Rise Rating.

Have been investigated by UL in accordance with the Standard(s) indicated on this Certificate.

Standard(s) for Safety: ANSI/UL 10B, Fire Tests of Door Assemblies
Additional Information: See the UL Online Certifications Directory at www.ul.com/database for additional information

Only those products bearing the UL Certification Mark should be considered as being covered by UL's Certification and Follow-Up Service.

Look for the UL Certification Mark on the product.

UL or any authorized licensee of UL. For questions, please

UL Certification* (Fire Barrier)

CERTIFICATE OF COMPLIANCE

Certificate Number R40146
Report Reference R40146-20220524
Date 2022-May-25

Issued to: Sigma Factory for Steel Products
 Saih Shuaib 3, 4 R/A Dubai Industrial City
 Opposite DEWA Substation
 Dubai AE

This is to certify that representative samples of MECHANICAL JOINT ASSEMBLIES
 The products covered by this Section are mechanical joint assemblies designated Nexus Fire Barrier (NFB) for use in various joint systems described in the Fire Resistance Directory.

Have been investigated by UL in accordance with the Standard(s) indicated on this Certificate.

Standard(s) for Safety: UL 2079, Tests for Fire Resistance of Building Joint Systems

Additional Information: See the UL Online Certifications Directory at <https://iq.ulprospector.com> for additional information

This Certificate of Compliance does not provide authorization to apply the UL Mark. Only the UL Follow-Up Services Procedure provides authorization to apply the UL Mark.

Only those products bearing the UL Mark should be considered as being UL Certified and covered under UL's Follow-Up Services.

Look for the UL Certification Mark on the product.

 Bruce Mahrenholz, Director North American Certification Program

UL LLC
 Any information and documentation involving UL Mark services are provided on behalf of UL LLC (UL) or any authorized licensee of UL. For questions, please contact a local UL Customer Service Representative at ul@ulprospector.com

SFSP Products

SFSP produces a variety of products ranging from cable management systems; cable trays, cable ladders, basket trays, trunkings and support systems, to mechanical cladding fixations, steel lintels and block work accessories, plasterers' beads, expanded metal and block work reinforcement, strut channel systems, pipe clamps & hangers, gypsum profiles as well as garbage and linen chutes. With the introduction of new machines and the enhancement of production methods, SFSP continues to develop its production methods systematically as well as thoroughly. Its design office in Stuttgart, Germany provides a comprehensive design and calculation case studies, enabling the factory to have the safety factors required for the usage of its products.



MEP Solutions

Cable Management Systems

Cable Management Systems are economical and designed to meet most requirements of cable and electrical wire installations and comply to international standards of fabrication and finishing.



Cable Trays & Accessories

Cable Trays are designed to meet most requirements of cable and electrical wire installations and comply to local and international standards of fabrications and finishes.

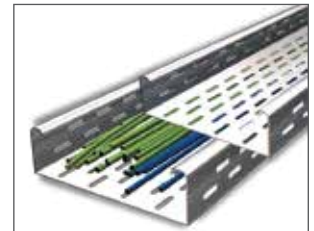

Cable Ladders (Welded & Swaged)

Cable Ladders of different side heights are available upon request.



Basket Trays & Accessories

SFSP's Basket Tray systems make connections fast and simple with limited need for tools. Its design allows for continuous airflow, and prevents heating up of cables. SFSP's Basket Tray comes in a full range of sizes and is made with high-strength welded steel wires.

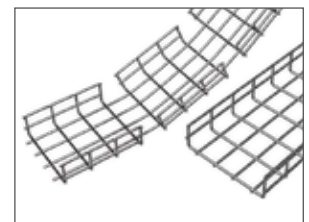

Cable Trunkings

Cable Trunkings and Accessories are offered in a comprehensive range. Mill galvanized, hot-dip galvanized, and powder coated are the various finishes produced in our factories.



Underfloor Trunking

Underfloor Trunking Systems solutions incorporate a range of products for the distribution of power and data services , it is a coordinated set of containments that protect, segregate, contain, and route cables within a given environment.



Fiberglass Reinforced Plastic (FRP) Cable Tray / Ladder

SFSP Fiberglass Reinforced Plastic (FRP) Cable Management Systems are designed, manufactured, and tested to be installed in most harsh environmental conditions of onshore and offshore facilities for several industries including Oil and Gas, Petrochemicals, Manufacturing, Mining and others.

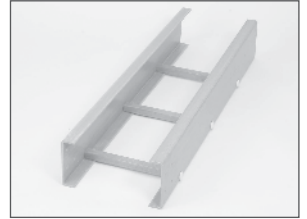

Cable Management Support Systems

Cable Support Systems are well designed to provide necessary support for cable trays, cable ladders and trunkings. Cable supports are manufactured according to common standards from high quality raw materials.

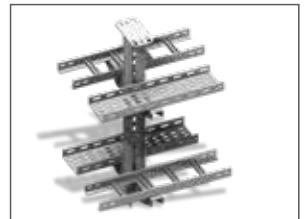

C-Channel Strut Systems

SFSP's Metal Framing Systems provide an economical solution for electrical, mechanical and industrial supports with a wide variety of applications in the construction industry.
Applications: - Pipe and Conduit Supports - Tunnel Pipe Stanchions - Racks and Shelvings - Wall Framings.



Pipe Clamps & Hangers

Pipe Clamps and Hangers from SFSP used in the support of pipes and equipments are manufactured according to the highest standards of fabrication. A diversified choice of Pipe Hangers, Pipe Clamps, EMT Straps, Omega Clamps, Beam Clamps, J and U-Bolts and Threaded Accessories.

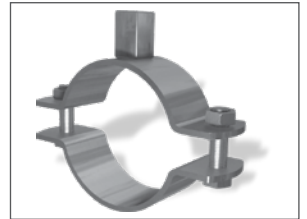

Galvanized Threaded Rods and Accessories

Threaded rod, often referred to as a stud, is a rod of varying length that is threaded in a helical structure. Similar in appearance to a screw, the threading extends around and along the rod to cause rotational movements when in use.



Access Panels by FEROX

Ferox Access Panels provides complete solutions of several types of access panels including Hook Type, Pivot Type, Tiled Type as well as fire rated access panels and hygienic access panels. A variety of finishes are available including stainless steel of different grades, galvanized steel with powder coating. Ferox Access Panels are manufactured from high quality material and assembled with stainless steel hardware.



Roof hatches by FEROX

Roof hatch provides safe and convenient access to commercial building roof areas using interior ladders and stairs for maintenance work. It can be installed on flat roofs with a maximum slope of 30°. Made of steel frames, doors and stainless steel hardware. Powder coated to provide corrosion resistance and outstanding exterior durability.





Architectural & Finishing Solutions

Mechanical Cladding Fixation (Stangle)

Stangle Cladding Fixation includes design, calculation and production of several types of mechanical fixings and accessories used for cladding purposes. Stainless and galvanized steel are among the various materials used in the fabrication.



Aluminium System for Stone Cladding

SFSP aluminum systems are designed and calculated to provide a practical & safe solutions of stone cladding. Wide range of aluminum profiles with different shapes to support different types of stone cladding.



Waste Management Sys. (Garbage & Linen Chutes)

Chutes from SFSP are very convenient, simple and low cost method of controlling and disposing of refuse and linen. Chutes meet the most stringent requirements of environmental health and safety.



Dry Wall & Ceiling Profiles

Gypsum Boards are considered among the most economic and ideal way for wall partitioning. Easy to install, saves time and money, gypsum boards can be used as a backing for wall treatments such as wall paper, fabric, tile and wood paneling or it can simply be painted.



Metal Ceiling Grid Systems

SFSP Ceiling Grid System is a practical, convenient ceiling system. It has a complete range of main c-channel sections and complementary parts so that you can adapt the modules to suit your design needs and load requirements.



Expansion Joint System by Nexus

Our variety of expansion joints includes profiles for walls and floors, profiles for seismic movements, watertight profiles. Our products suit pedestrian as well as heavy load traffic areas.



Entrance Matting System by Nexus

Nexus Entrance matting systems provides heavy duty entrance mats, composed of aluminium profiles with carpet, brushes or rubber inserts. For any design of any shape, being round, square, oval, or any other symmetrical or asymmetrical shape, Nexus offers a variety of entrance matting profiles



Profiles by Nexus

Nexus offer comprehensive solutions for the construction industry ranging from Expansion Joint Covers and Fire Barriers to Entrance Matting Systems, Wall and Floor Profiles, Tactile Solutions, etc... NEXUS range of products is manufactured according to most common international standards to meet the requirements of commercial, residential, governmental, transportation, healthcare and educational projects.



Phenolic Compartment by CUBIX

CUBIX phenolic compartment and partition systems are manufactured and customized to meet the precise needs of simple to complicated projects with its top-notch finish, quality of material and within a timely delivery. A complete solution with a wide selection of colors and textures are available.



Raised Access Flooring by PIXEL

PIXEL Raised Access Flooring offers comprehensive solutions of High Tech Raised Access Flooring Systems for the construction industry. PIXEL Raised Access Flooring are manufactured according to most common international standards to meet the requirements of commercial, residential, governmental, transportation, healthcare, and educational projects.

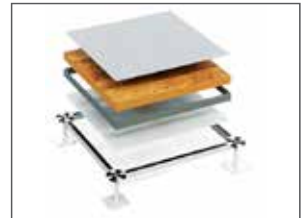

Civil Solutions

Expanded Metals, Plasterers' Beads

Expanded Metals help the formation of joints, protection of corners and resistance against cracks, chips and impact damage. SFSP manufactures in accordance with BS EN 13658 - 2, ASTM C847-18, BS EN 845-3:2003+A1:2008, ASTM A 951/A 951M - 2016 standards.

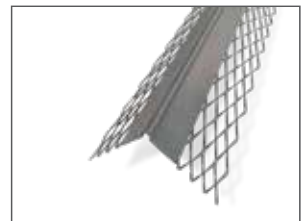

Block Ladder Reinforcement

SFSP ladder and truss types are used for the reinforcement of brick and block masonry to give improved tensile strength to walls subjected to lateral loading e.g. wind and seismic. SFSP Block reinforcements reduces the risk of cracking either at stress concentration around opening.



Steel Lintels & Block Work Accessories

Steel Lintels provide a combination of strength and light weight, resulting in efficient load bearing performance and increased productivity on site. They are characterized by their ease of installation in addition to time as well as money saving. SFSP manufactures Steel Lintel in accordance with BS EN 845-2:2013+A1:2016 and according to relevant standards BS 5977 Part 2:1983.



SFSP Products are solely distributed by UNITECH for Building and Construction Materials

All Products Manufactured by Sfsp are Solely Distributed by SFSP Sister Companies in the Following Countries

KSA

Isam Kabbani & Partners for Building and Construction Materials Co., Ltd.

شركة عصام قباني وشركاه لمواد الأنشاء والتعمير المحدودة

BAHRAIN

Isam Kabbani Trading Est.

مؤسسة عصام قباني التجارية

UAE

Issam Kabbani Trading Company LL

شركة عصام قباني للتجارة

EGYPT

Unitech Egypt for Building Materials

شركة يونيتك مصر لمواد البناء

OMAN

Isam Kabbani & Partners Trading Co.

شركة عصام قباني وشركاه للتجارة

QATAR

Unitech Qatar for Building & Construction Materials Ltd., W.L.L

شركة يونيتك قطر لمواد الانشاء والتعمير المحدودة

KUWAIT

Hassan Kabbani for General Contracting Est.

مؤسسة حسان قباني للمقاولات العامة للمباني

LEBANON

Unitech ME s.a.r.l

شركة يونيتك ميدل إيست ش.م.م

PAKISTAN

Unitech IKK Pakistan (PVT.) LTD.

شركة يونيتك ميدل إيست ش.م.م

SFSP CUSTOMER SERVICE CALL CENTER

KSA

+966 13 8590097, Ext. 3214

UAE

+971 4 8181925, Ext. 4269



CABLE MANAGEMENT SYSTEMS

SFSP Cable Management Systems, fittings and accessories are manufactured in compliance with international standards. SFSP provides a wide range of products capable of providing the characteristics which respond to the proposed application, along with quality of assembly, speed of installation and cost-saving Cable Management Systems. Calculations are provided by our design office in Stuttgart, Germany.

SFSP Cable Management Systems are designed to meet most requirements of cable and electrical wire installations and comply to local and international standards of fabrication and finishing. Cable Management Systems are economical wire and cable management systems designed to support and protect electrical wires and cables.

National Electric Code (NEC) permits Cable Trays in a wide variety of indoor and outdoor applications. The NEC also permits Cable Trays for use as equipment ground conductor.

Cable Management Systems can provide significant advantages in cable filling over other wiring methods. This can provide savings in the size or number of raceways required, thereby, reducing both material and labor costs. In many cases, NEC permits greater conductor ampacities in Cable Tray Systems than for other wiring methods.

Under certain conditions, the NEC allows "Free Air" rating of large, single conductor power cables (4/0 & larger) in ventilated Cable Management Systems. This can provide significant savings in conductor costs. Cable Management Systems permit much greater spacing between support hangers than most other systems, providing savings in support costs and installation labor.

Cable Management Systems' types fittings and accessories from SFSP are manufactured in compliance with :

- ▶ IEC 61537:2023
- ▶ BS EN 61537:2007 International Electrotechnical Commission (Cable Management, Cable Tray Systems and Cable Ladder Systems)
- ▶ SASO IEC (61537:2006) Saudi Standard (Cable Management, Cable Tray Systems and Cable Ladder Systems)
- ▶ NEMA VE-1:2017 National Electrical Manufacturers Association (Metal Cable Tray Systems)
- ▶ NEMA VE-2:2023 National Electrical Manufacturers Association (Metal Cable Tray Installation Guide Lines)
- ▶ NEC (ANSI / NFPA 70) National Electric Code (Metal Cable Tray Guide Lines)

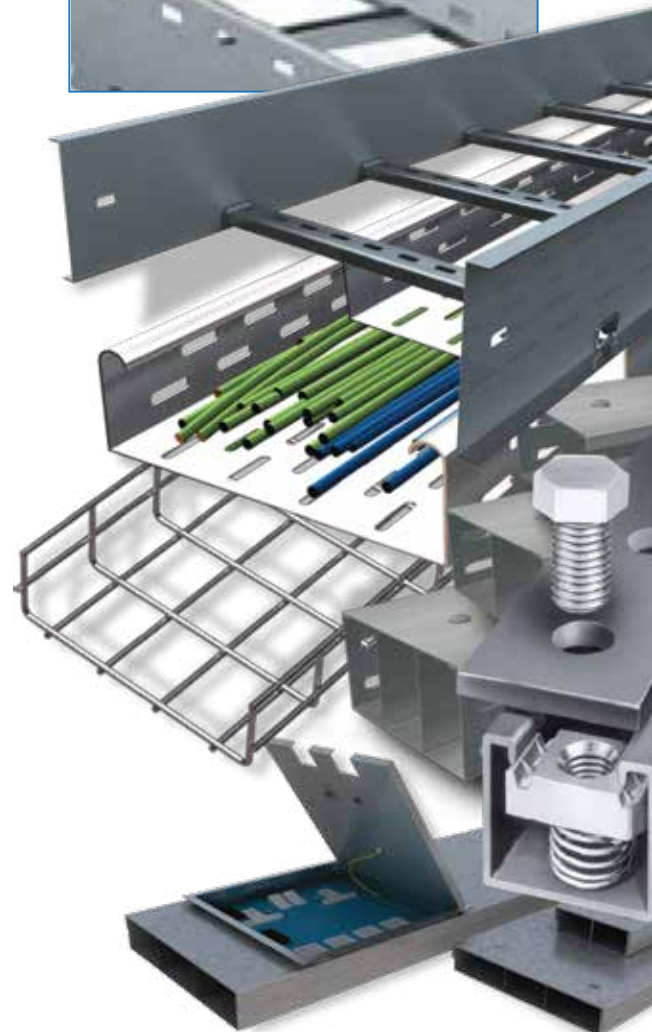

CABLE TRAYS RUNS

Cable Trays, are designed to meet most requirements of cable and electrical wire installations and comply to local and international standards of fabrication and finishing.

This catalogue is designed to be helpful to engineers and contractors in the application and selection of tray products for construction and maintenance. If a unique application requires a special product not included in this catalogue, SFSP engineering personnel are ready to furnish design consultation and realistic cost estimates. In addition, our know-how is available for your convenience.

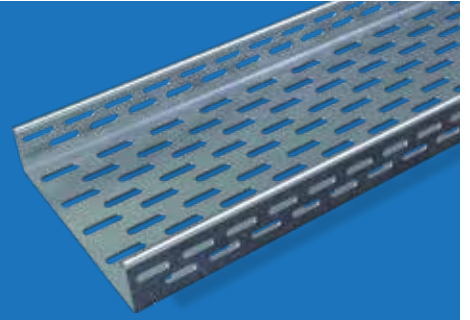

Products Range

Ladder (Cable Ladder)

Swaged rounded tubular (Aluminum or Steel) or welded c-channel (steel). A prefabricated metal structure consisting of two side rails connected by individual transverse members or rungs. Cable Ladder Trays are the most common and the most economical types of trays.

They also provide maximum ventilation for cabling.

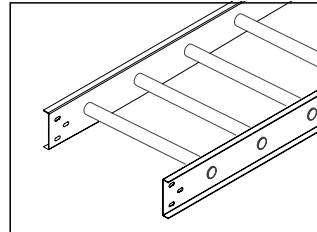

Swaged Rounded Tubular

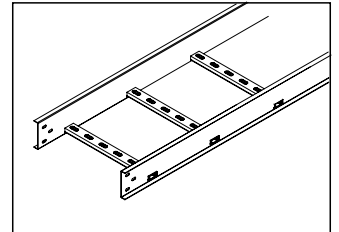

Welded C-Channel

Perforated Cable Tray (Cable Trays)

A prefabricated metal structure consisting of a bottom with openings within the cable bearing surface.

Solid bottom Cable Trays completely eliminate cable sagging and offer maximum protection for the cables.

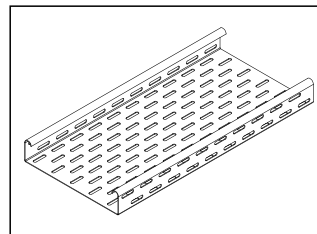

Perforated Cable Tray

Wire Mesh (Basket Tray)

Is ideally suitable for light - to medium-duty commercial and industrial applications where space is at a premium. SFSP wire Basket Trays have a fast connection profile for installations requiring long runs of straight Cable Trays lengths. Applications : Network cabling, wiring closets, fiber-to-desktop applications and can often be used in suspended ceiling plenum areas and under computer room flooring.

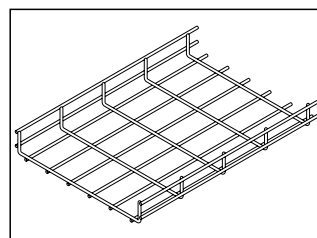

Wire Mesh

Solid (Cable Trunking)

A prefabricated metal structure consisting of a one-piece solid bottom channel section not exceeding 6"(150mm) in width.

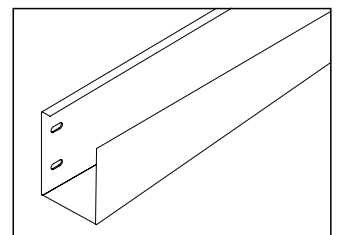
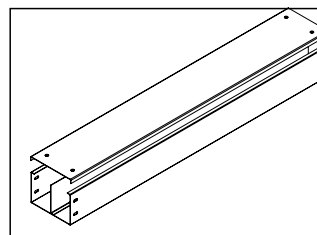

Cable Trunking

Types Overview and Components

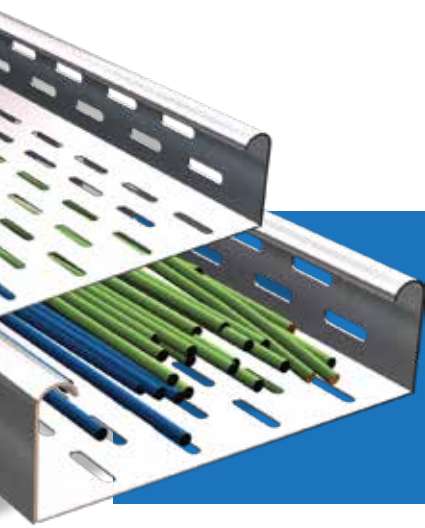

: SFSP cable trays and accessories from SFSP are manufactured in compliance with BS EN 61537:2007/BS EN 10130/BS EN 10131/ BS EN 10051 and NEMA standards, and as per cabling standards CENELEC EN 50173-1; EIA/ITA 568 A; ISO/IEC 11801-1:2017.

We manufacture a wide range of products capable of providing the characteristics which respond to the proposed application, along with quality of assembly, speed of installation, and cost-saving cable trays.

MATERIALS

Pre-Galvanized, Hot-Dip Galvanized, Stainless Steel and Aluminium

MATERIAL THICKNESS

1.00 mm | 1.20 mm | 1.50 mm | 2.00 mm

* Other Thickness Available Under Request

Light Duty - LCT - 100

Thickness : 1.00 mm
Side Height : 50 mm
Length : 2440 mm / 3000 mm
Width : 50 - 1000 mm

Medium Duty - MCT - 120

Thickness : 1.20 mm
Side Height : 50 ,75 and 100 mm
Length : 2440 mm / 3000 mm
Width : 50 - 1000 mm

Heavy Duty - HCT - 150

Thickness : 1.50 mm
Side Height : 50 ,75 and 100 mm
Length : 2440 mm / 3000 mm
Width : 50 - 1000 mm

Very Heavy Duty - VCT - 200

Thickness : 2.00 mm
Side Height : 50 ,75 and 100 mm
Length : 2440 mm / 3000 mm
Width : 50 - 1000 mm

TYPES OF SIDE HEIGHTS

STR

Straight

RFI

Return Flange Inside

RFO

Return Flange Outside

CTI

C-Type Inside

CTO

C-Type Outside

TYPES OF PERFORATION

Staggered

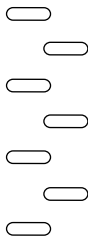

Serial

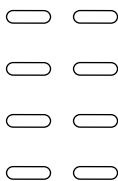

DIMENSIONS

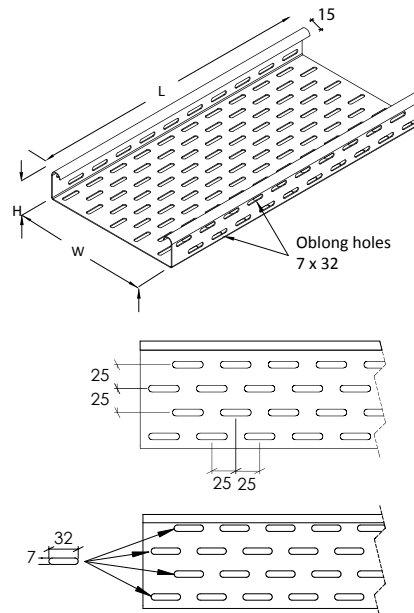

All illustrations, drawings and descriptive material in this publication are of a generally informative nature only, and do not form a complete package of the specifications or description of the goods. Most of the dimensions shown are nominal. SFSP can make modifications and design, materials or finishes as it deems necessary or desirable.

Materials & Finishes

Materials

Mild Steel - Plain

A. Hot Rolled Steel Plates, Sheets and Coils **S235 JR**, as per:

EN 10025 -2 / DIN 17100 / BS 4360 / ASTM A 653M / ASTM A 1011 / ASTM A 1011-01a

JIS 3101 / JIS 3106 / GB 700 / GB / T1591.

ASTM A 907 / ASTM A 1018M.

ASTM A 570M / ASTM A 572M.

B. Cold Rolled Steel **DC 01**, as per:

EN 10130 / DIN 1623, Part 2 / BS 1449:1 / ASTM A366 / ASTM A 1008 / JIS G 3141 / GB 699.

EN 10131 / ASTM A 568M



Mild Steel - Galvanized

C. Continuously Pre-Galvanized Hot-Dip Zinc Coated Steel **DX 51D + Z**, as per:

EN 10327 / DIN 17162 / BS 2989/ ASTM A 527M / ASTM A 653M / JIS G 3302.

EN 10326/ EN 10142 / ASTM A 526, 527, 528/ ASTM A 146

D. Electro Galvanized Steel (Electrolytic Coating) **DC01 + ZE v**, as per:

EN 10152 / DIN 17163 / ASTM A591 / JIS G 3313 / JIS G 3141/BS 1449:1

EN 10131

Aluminum

E. Aluminum **6063 T6**

Stainless Steel

F. Austenitic Stainless Steels **SS 304 & SS 316**, as per:

ASTM A 240 /EN 10088-2/ DIN 17400 / BS 1449:2 / ASTM A480 / ASTM A666 / ISO 3506 / EN 10028-7 /JIS G 4304

F1 Stainless Steel Fasteners EN 3506

F2 Stainless Steel Wire BS 1554 ,ASTM A276

Finishes

1- Hot-DIP Galvanization after Fabrication

as per:

ASTM A 123 / ASTM A 153 / ISO 1461.

BS 729 / DIN 50976

2- Zinc Electroplating after Fabrication

as per:

ASTM B633 / EN 12329 / ISO 4042/ BS 1706 / BS 3382 / DIN 50961

3- Powder Coating

Epoxy / Polyester / Epoxy & Polyester

BS 3900 / ISO 2409 / ISO 1519 / ISO 1520



LCT - 50

Light Duty -1.00 mm Thickness

(Side Height 50 mm)

Thickness : 1.00 mm
Side Height : 50 mm
Length : 3000 mm
Width : 50 - 300 mm
Safety : 1.5

Item Code	Cable tray	Support distance (m)	Load kN/m
SVCTBS_F_00012382	LCT 50 -50	1.00	1.92
	width (w) : 50 mm	1.20	1.33
		1.50	0.84
		2.00	0.40
SVCTBS_F_00071213	LCT 100 -50	1.00	2.10
	width (w) : 100 mm	1.20	1.45
		1.50	0.92
		2.00	0.50
SVCTBS_F_00097887	LCT 150 -50	1.00	2.19
	width (w) : 150 mm	1.20	1.50
		1.50	0.96
		2.00	0.53
SVCTBS_F_00071221	LCT 200 -50	1.00	1.73
	width (w) : 200 mm	1.20	1.13
		1.50	0.72
		2.00	0.39
SVCTBS_F_00097763	LCT 225 -50	1.00	1.52
	width (w) : 225 mm	1.20	1.13
		1.50	0.72
		2.00	0.39
SVCTBS_F_00205959	LCT 300 -50	1.00	0.87
	width (w) : 300 mm	1.20	0.59
		1.50	0.37
		2.00	0.19

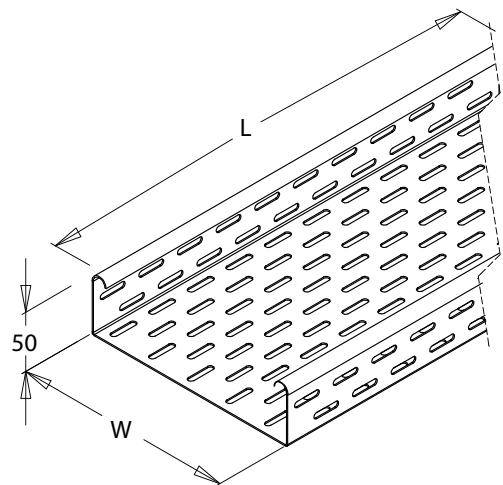

Width (mm)	Order Example				
	Item	(h)	(w)	(t)	Type
50	LCT50	050	0050	1	RFI
100	LCT50	050	0100	1	RFI

Order Example:
LCT50 - Side height (h) - Width(w) - Thickness - Side type
For more ordering details, please check pages 64-65

MCT - 50

Medium Duty - 1.20 mm Thickness

(Side Height 50 mm)

Thickness : 1.20 mm
Side Height : 50 mm
Length : 3000 mm
Width : 50 - 600 mm
Safety : 1.5

Item Code	Cable tray	Support distance (m)	Load kN/m
SVCTBS_F_00012374	MCT 50 - 50	1.00	2.29
	width (w) : 50 mm	1.20	1.59
		1.50	1.01
		2.00	0.48
SVCTBS_F_00282028	MCT 100 - 50	1.00	2.51
	width (w) : 100 mm	1.20	1.74
		1.50	1.10
		2.00	0.60
SVCTBS_F_00159703	MCT 150 - 50	1.00	2.62
	width (w) : 150 mm	1.20	1.80
		1.50	1.15
		2.00	0.63
SVCTBS_F_00053189	MCT 200 - 50	1.00	2.48
	width (w) : 200	1.20	1.85
		1.50	1.17
		2.00	0.65
SVCTBS_F_00077529	MCT 225 - 50	1.00	2.20
	width (w) : 225	1.20	1.85
		1.50	1.18
		2.00	0.65
SVCTBS_F_00121325	MCT 300 - 50	1.00	1.52
	width (w) : 300	1.20	1.04
		1.50	0.65
		2.00	0.35
SVCTBS_F_00174727	MCT 400 - 50	0.80	-
	width (w) : 400	1.00	0.80
		1.20	0.54
		1.50	0.33
SVCTBS_F_00102687	MCT 450 - 50	0.80	-
	width (w) : 450	1.00	0.61
		1.20	0.41
		1.50	0.24
SVCTBS_F_00138675	MCT 600 - 50	0.60	-
	width (w) : 600	0.80	-
		1.00	-
		1.20	-

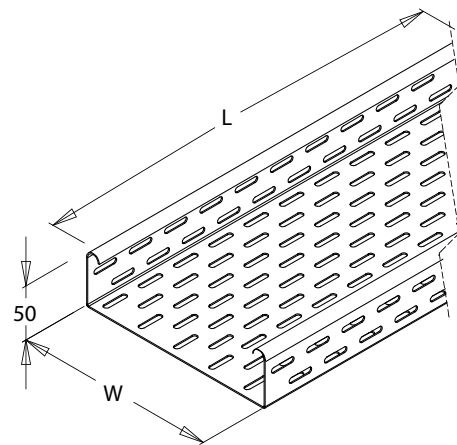
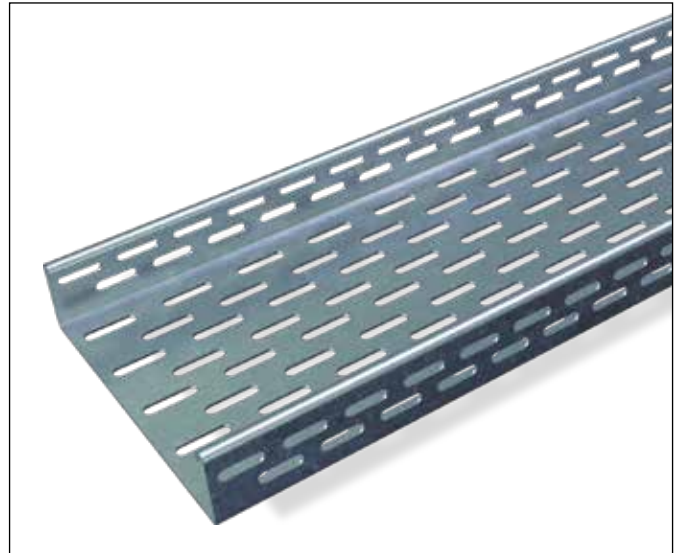

Width (mm)	Order Example				
	Item	(h)	(w)	(t)	Type
50	MCT50	050	0050	2	RFI
100	MCT50	050	0100	2	RFI

Order Example:
MCT50 - Side height (h) - Width(w) - Thickness - Side type
For more ordering details, please check pages 64-65

MCT - 75

Medium Duty - 1.20 mm Thickness

(Side Height 75 mm)

Thickness : 1.20 mm
 Side Height : 75 mm
 Length : 2440 mm / 3000 mm
 Width : 100 - 600 mm
 Safety : 1.5

Item Code	Cable tray	Support distance (m)	Load kN/m
SVCTBS_F_00091413	MCT 100 - 75	1.00	1.50
	width (w) : 100 mm	1.20	1.50
		1.50	1.50
SVCTBS_F_00011414	MCT 150 - 75	1.00	1.50
	width (w) : 150 mm	1.20	1.50
		1.50	1.50
SVCTBS_F_00012214	MCT 200 - 75	1.00	1.50
	width (w) : 200	1.20	1.50
		1.50	1.50
SVCTBS_F_00199827	MCT 225 - 75	1.00	1.50
	width (w) : 225	1.20	1.50
		1.50	1.50
SVCTBS_F_00106587	MCT 300 - 75	1.00	1.30
	width (w) : 300	1.20	1.30
		1.50	1.30
SVCTBS_F_00010702	MCT 400 - 75	0.80	0.80
	width (w) : 400	1.00	0.80
		1.20	0.80
SVCTBS_F_00319386	MCT 450 - 75	0.80	0.70
	width (w) : 450	1.00	0.70
		1.20	0.70
SVCTBS_F_00319394	MCT 600 - 75	0.80	0.50
	width (w) : 600	1.00	0.50
		1.20	0.40
		1.50	0.25

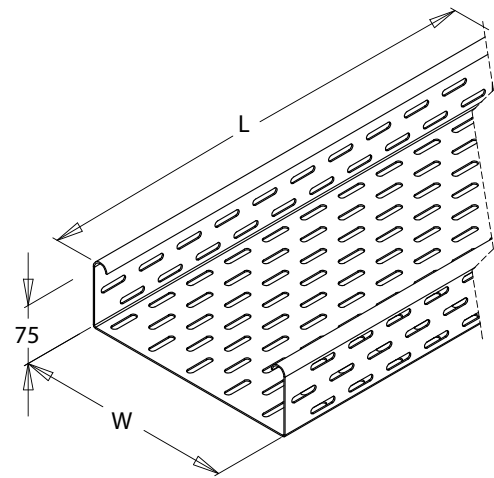

Width (mm)	Order Example				
	Item	(h)	(w)	(t)	Type
50	MCT75	075	0100	2	RFI
100	MCT75	075	0150	2	RFI

Order Example:
 MCT25 - Side height (h) - Width(w) - Thickness - Side type
 For more ordering details, please check pages 64-65

MCT - 100

Medium Duty - 1.20 mm Thickness

(Side Height 100 mm)

Thickness : 1.20 mm
 Side Height : 100 mm
 Length : 3000 mm
 Width : 50 - 600 mm
 Safety : 1.5

Item Code	Cable tray	Support distance (m)	Load kN/m
SVCTBS_F_00016702	MCT 100 - 100	1.00	1.50
	width (w) : 100 mm	1.20	1.50
		1.50	1.50
SVCTBS_F_00011514	MCT 150 - 100	1.00	1.50
	width (w) : 150 mm	1.20	1.50
		1.50	1.50
SVCTBS_F_00012358	MCT 200 - 100	1.00	1.50
	width (w) : 200 mm	1.20	1.50
		1.50	1.50
SVCTBS_F_00057879	MCT 225 - 100	1.00	1.50
	width (w) : 225 mm	1.20	1.50
		1.50	1.50
SVCTBS_F_00041498	MCT 300 - 100	1.00	1.20
	width (w) : 300 mm	1.20	1.20
		1.50	1.20
SVCTBS_F_00207375	MCT 400 - 100	1.00	1.00
	width (w) : 400 mm	1.20	1.00
		1.50	0.90
SVCTBS_F_00253047	MCT 600 - 100	1.00	0.90
	width (w) : 600 mm	1.20	0.80
		1.50	0.70
		2.00	0.40

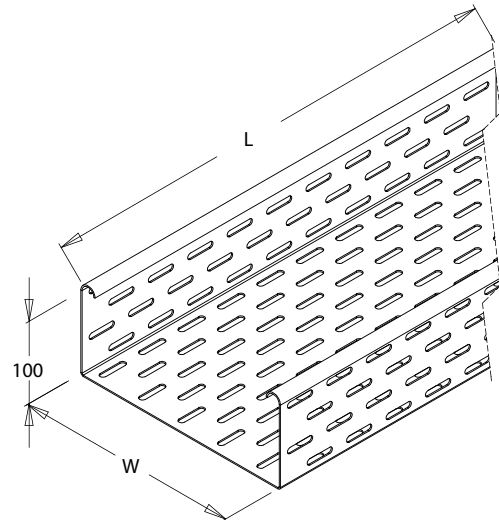
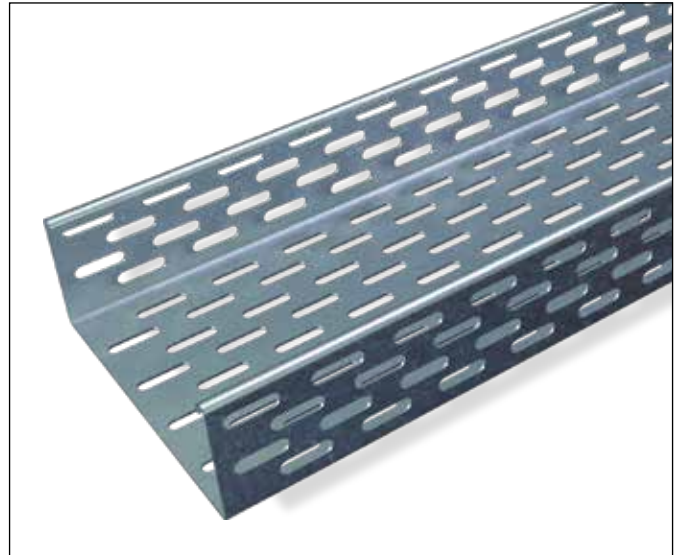

Width (mm)	Order Example				
	Item	(h)	(w)	(t)	Type
100	MCT100	0100	0100	2	RFI
150	MCT150	0100	0150	2	RFI

Order Example:
 MCT100 - Side height (h) - Width(w) - Thickness - Side type
 For more ordering details, please check pages 64-65

HCT - 50

Heavy Duty - 1.50 mm Thickness

(Side Height 50 mm)

Thickness : 1.50mm
 Side Height : 50 mm
 Length : 2440 mm / 3000 mm
 Width : 50 - 900 mm
 Safety : 1.5

Item Code	Cable tray	Support distance (m)	Load kN/m
SVCTBS_F_00012398	HCT 50 - 50	1.00	1.50
	width (w) : 50 mm	1.20	1.50
		1.50	1.25
SVCTBS_F_00273771	HCT 100 - 50	1.00	1.50
	width (w) : 100 mm	1.20	1.50
		1.50	1.35
SVCTBS_F_00057311	HCT 150 - 50	1.00	1.50
	width (w) : 150 mm	1.20	1.50
		1.50	1.45
SVCTBS_F_00073919	HCT 200 - 50	1.00	1.50
	width (w) : 200	1.20	1.50
		1.50	1.45
SVCTBS_F_00096121	HCT 225 - 50	1.00	1.50
	width (w) : 225	1.20	1.50
		1.50	1.45
SVCTBS_F_00266161	HCT 300 - 50	1.00	1.50
	width (w) : 300	1.20	1.50
		1.50	1.30
SVCTBS_F_00042558	HCT 400 - 50	0.80	1.50
	width (w) : 400	1.00	1.50
		1.20	1.00
SVCTBS_F_00304968	HCT 450 - 50	0.80	1.50
	width (w) : 450	1.00	1.20
		1.20	0.80
SVCTBS_F_00068495	HCT 500 - 50	0.80	1.40
	width (w) : 500	1.00	0.95
		1.20	0.65
SVCTBS_F_00052937	HCT 600 - 50	0.80	1.00
	width (w) : 600	1.00	0.60
		1.20	0.40

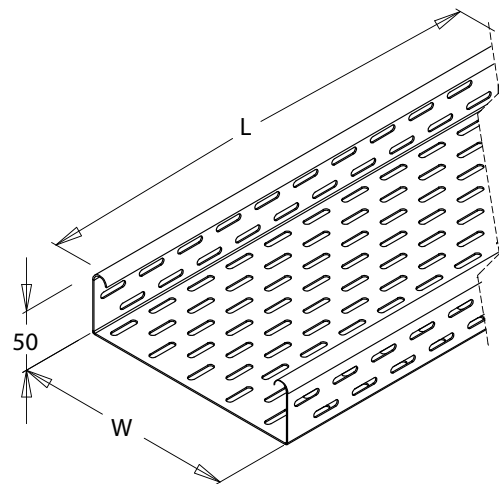
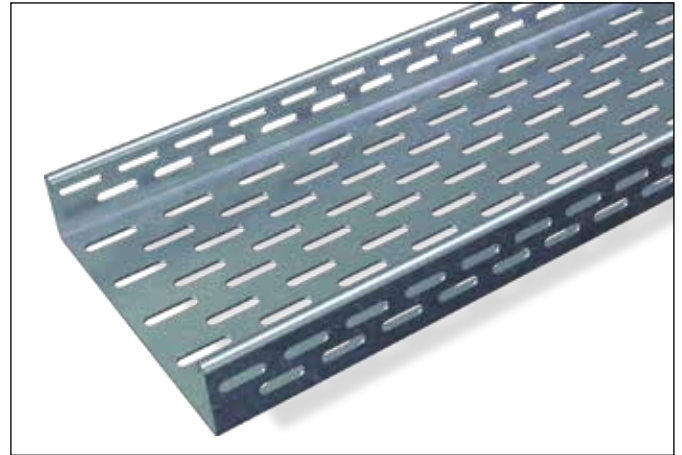

SVCTBS_F_00304716	HCT 750 - 50	0.60	0.50
	width (w) : 750	0.80	0.50
		1.00	0.30
SVCTBS_F_00053673	HCT 900 - 50	0.60	0.30
	width (w) : 900 mm	0.80	0.30
		1.00	0.20

Width (mm)	Order Example				
	Item	(h)	(w)	(t)	Type
50	HCT50	050	0050	3	RFI
100	HCT50	050	0100	3	RFI

Order Example:
 HCT50 - Side height (h) - Width(w) - Thickness - Side type
 For more ordering details, please check pages 64-65

HCT - 75

Heavy Duty - 1.50 mm Thickness

(Side Height 75 mm)

Thickness : 1.50 mm
 Side Height : 75 mm
 Length : 2440 mm / 3000 mm
 Width : 100 - 900 mm
 Safety : 1.5

Item Code	Cable tray	Support distance (m)	Load kN/m
SVCTBS_F_00060171	HCT 100 -75	1.00	1.50
	width (w) : 100 mm	1.20	1.50
		1.50	1.50
SVCTBS_F_00011430	HCT 150 -75	1.00	1.50
	width (w) : 150 mm	1.20	1.50
		1.50	1.50
SVCTBS_F_00012230	HCT 200 -75	1.00	1.50
	width (w) : 200 mm	1.20	1.50
		1.50	1.50
SVCTBS_F_00060343	HCT 225 -75	1.00	1.50
	width (w) : 225 mm	1.20	1.50
		1.50	1.50
SVCTBS_F_00060335	HCT 300 -75	1.00	1.50
	width (w) : 300 mm	1.20	1.50
		1.50	1.50
SVCTBS_F_00073111	HCT 400 -75	1.00	1.30
	width (w) : 400 mm	1.20	1.30
		1.50	1.30
SVCTBS_F_00144505	HCT 450 -75	1.00	1.20
	width (w) : 450 mm	1.20	1.20
		1.50	1.00
SVCTBS_F_00148981	HCT 500 -75	1.00	1.00
	width (w) : 500 mm	1.20	1.00
		1.50	0.85
SVCTBS_F_00077517	HCT 600 -75	0.80	0.80
	width 600 mm	1.00	0.80
		1.20	0.80
SVCTBS_F_00150165	HCT 750 -75	0.60	0.60
	width 750 mm	0.80	0.60
		1.00	0.60
		1.20	0.50

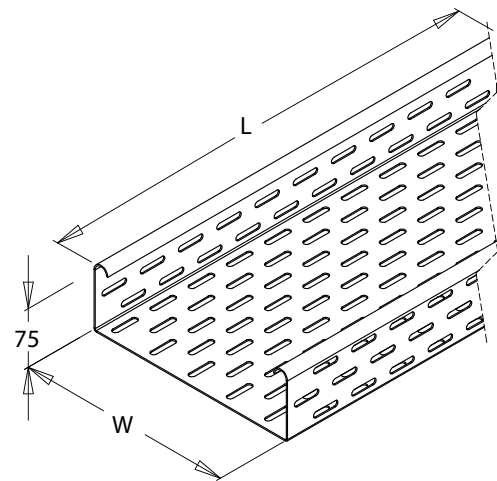
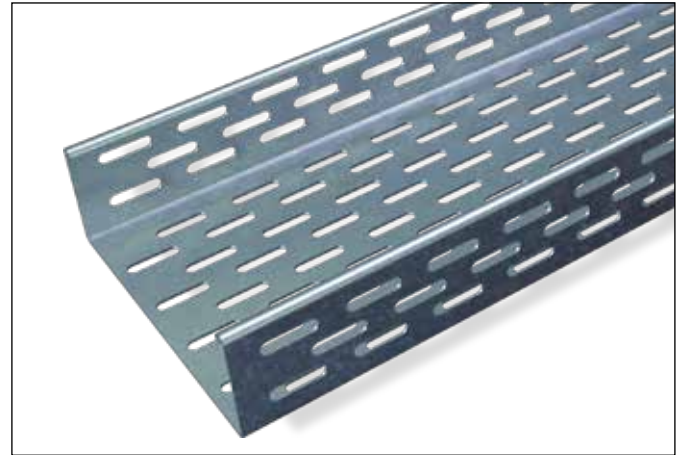

Item Code	Cable tray	Support distance (m)	Load kN/m
SVCTBS_F_00150165	HCT 900 - 75	0.60	0.50
	width (w) : 900 mm	0.80	0.50
		1.00	0.40
		1.20	0.30

Width (mm)	Order Example				
	Item	(h)	(w)	(t)	Type
100	HCT75	075	0100	3	RFI
150	HCT75	075	0150	3	RFI

Order Example:
 HCT75 - Side height (h) - Width(w) - Thickness - Side type
 For more ordering details, please check pages 64-65

HCT - 100

Heavy Duty - 1.50 mm Thickness

(Side Height 100 mm)

Thickness : 1.50 mm
 Side Height : 100 mm
 Length : 2440 mm / 3000 mm
 Width : 100 - 900 mm
 Safety : 1.5

Item Code	Cable tray	Support distance (m)	Load kN/m
SVCTBS_F_00073135	HCT 100 - 100	1.00	1.50
	width (w) : 100 mm	1.20	1.50
		1.50	1.50
SVCTBS_F_00011530	HCT 150 - 100	1.00	1.50
	width (w) : 150 mm	1.20	1.50
		1.50	1.50
SVCTBS_F_00012318	HCT 200 - 100	1.00	1.50
	width (w) : 200 mm	1.20	1.50
		1.50	1.50
SVCTBS_F_00016678	HCT 225 - 100	1.00	1.50
	width (w) : 225 mm	1.20	1.50
		1.50	1.50
SVCTBS_F_00042514	HCT 300 - 100	1.00	1.50
	width (w) : 300 mm	1.20	1.50
		1.50	1.50
SVCTBS_F_00142339	HCT 400 - 100	1.00	1.50
	width (w) : 400 mm	1.20	1.40
		1.50	1.10
SVCTBS_F_00065369	HCT 450 - 100	1.00	1.50
	width (w) : 450 mm	1.20	1.40
		1.50	1.10
SVCTBS_F_00120951	HCT 500 - 100	1.00	1.40
	width (w) : 500 mm	1.20	1.40
		1.50	1.10
SVCTBS_F_00170705	HCT 600 - 100	0.80	1.20
	width (w) : 600 mm	1.00	1.20
		1.20	1.20
SVCTBS_F_00012042	HCT 750 - 100	0.60	0.920
	width (w) : 750 mm	0.80	0.90
		1.00	0.90
		1.20	0.90

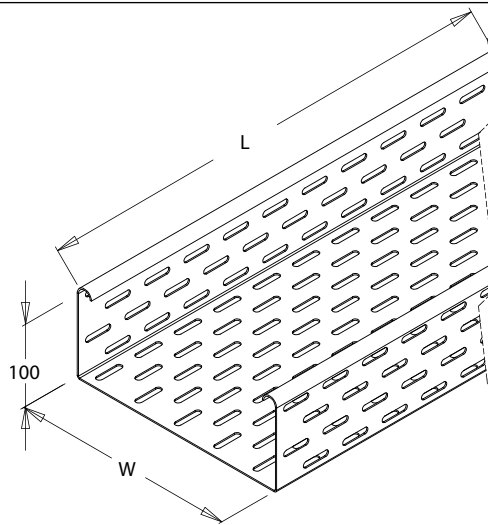
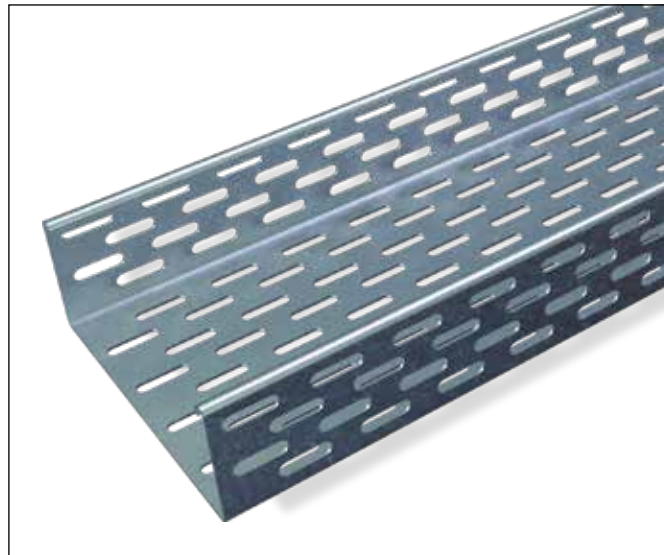

Item Code	Support distance (m)	Load kN/m
SVCTBS_F_00053673	HCT 900 - 50	0.60
	width (w) : 900 mm	0.70
		0.80
	1.00	0.70
	1.20	0.60

Width (mm)	Order Example				
	Item	(h)	(w)	(t)	Type
100	HCT100	0100	0100	3	RFI
150	HCT100	0100	0150	3	RFI

Order Example:
 HCT100 - Side height (h) - Width(w) - Thickness - Side type
 For more ordering details, please check pages 64-65

VCT - 50

Very Heavy Duty -2.00 mm Thickness

(Side Height 50 mm)

Thickness : 2.0 mm
 Side Height : 50 mm
 Length : 2440 mm / 3000 mm
 Width : 50 - 1000 mm
 Safety : 1.5

Item Code	Cable tray	Support distance (m)	Load kN/m
SVCTBS_F_00091125	VCT 50 - 50	1.00	1.50
	width (w) : 50 mm	1.20	1.50
		1.50	1.50
SVCTBS_F_00151147	VCT 100 - 50	1.00	1.50
	width (w) : 100 mm	1.20	1.50
		1.50	1.50
SVCTBS_F_00151139	VCT 150 - 50	1.00	1.50
	width (w) : 150 mm	1.20	1.50
		1.50	1.50
SVCTBS_F_00145147	VCT 200 - 50	1.00	1.50
	width (w) : 200	1.20	1.50
		1.50	1.50
SVCTBS_F_00151127	VCT 225 - 50	1.00	1.50
	width (w) : 225	1.20	1.50
		1.50	1.50
SVCTBS_F_00147255	VCT 300 - 50	1.00	1.50
	width (w) : 300	1.20	1.50
		1.50	1.50
SVCTBS_F_00140957	VCT 400 - 50	1.00	1.50
	width (w) : 400	1.20	1.50
		1.50	1.50
SVCTBS_F_00081757	VCT 450 - 50	1.00	1.50
	width (w) : 450	1.20	1.50
		1.50	1.20
SVCTBS_F_00121953	VCT 500 - 50	1.00	1.50
	width (w) : 500	1.20	1.50
		1.50	1.00
SVCTBS_F_00053205	VCT 600 - 50	0.80	1.50
	width (w) : 600	1.00	1.30
		1.20	1.00
SVCTBS_F_00011822	VCT 750 - 50	0.60	1.30
	width (w) : 750	0.80	1.30
		1.00	0.90
SVCTBS_F_00086265	VCT 900 - 50	0.60	0.90
	width (w) : 900 mm	0.80	0.90
		1.00	0.90
SVCTBS_F_00012034	VCT 1000 - 50	1.20	0.60
	width (w) : 1000 mm	0.80	0.60
		1.00	0.40
SVCTBS_F_00012034	VCT 1000 - 50	1.20	0.20
		1.00	0.40
		0.80	0.60

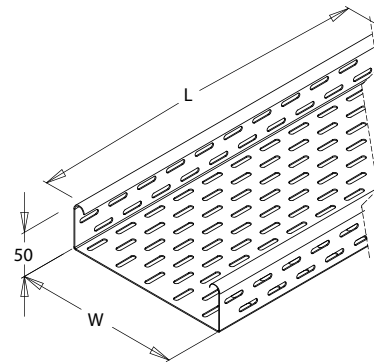
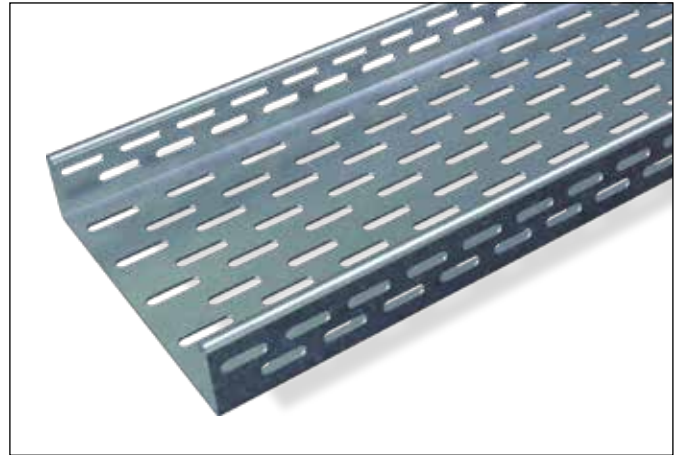

SVCTBS_F_00011822	VCT 750 - 50	0.60	1.30
	width (w) : 750	0.80	1.30
		1.00	0.90
SVCTBS_F_00086265	VCT 900 - 50	0.60	0.90
	width (w) : 900 mm	0.80	0.90
		1.00	0.90
SVCTBS_F_00012034	VCT 1000 - 50	1.20	0.60
	width (w) : 1000 mm	0.80	0.60
		1.00	0.40
SVCTBS_F_00012034	VCT 1000 - 50	1.20	0.20
		1.00	0.40
		0.80	0.60

Width (mm)	Order Example				
	Item	(h)	(w)	(t)	Type
50	VCT50	050	0050	4	RFI
50	VCT50	050	0050	4	RFI
100	VCT50	050	0100	4	RFI
100	VCT50	050	0100	4	RFI

Order Example:
 VCT50 - Side height (h) - Width(w) - Thickness - Side type
 For more ordering details, please check pages 64-65

VCT - 75

Very Heavy Duty -2.00 mm Thickness

(Side Height 75 mm)

Thickness : 2.0 mm
 Side Height : 75 mm
 Length : 2440 mm / 3000 mm
 Width : 100 - 1000 mm
 Safety : 1.5

Item Code	Cable tray	Support distance (m)	Load kN/m
SVCTBS_F_00238749	VCT 100 - 75	1.00	1.50
	width (w) : 100 mm	1.20	1.50
		1.50	1.50
SVCTBS_F_00011462	VCT 150 - 75	1.00	1.50
	width (w) : 150 mm	1.20	1.50
		1.50	1.50
SVCTBS_F_00012262	VCT 200 - 75	1.00	1.50
	width (w) : 200	1.20	1.50
		1.50	1.50
SVCTBS_F_00209099	VCT 300 - 75	1.00	1.50
	width (w) : 300	1.20	1.50
		1.50	1.50
SVCTBS_F_00293584	VCT 400 - 75	1.00	1.50
	width (w) : 400	1.20	1.50
		1.50	1.50
SVCTBS_F_00060327	VCT 450 - 75	1.00	1.50
	width (w) : 450	1.20	1.50
		1.50	1.20
SVCTBS_F_00293754	VCT 500 - 75	1.00	1.50
	width (w) : 500	1.20	1.50
		1.50	1.00
SVCTBS_F_00055943	VCT 600 - 75	1.00	1.50
	width (w) : 600	1.20	1.15
		1.50	0.65
SVCTBS_F_00153571	VCT 750 - 75	0.80	1.20
	width (w) : 750	1.00	1.20
		1.20	1.20
SVCTBS_F_00055935	VCT 900 - 75	0.60	0.90
	width (w) : 900	0.80	0.90
		1.00	0.90
		1.20	0.80

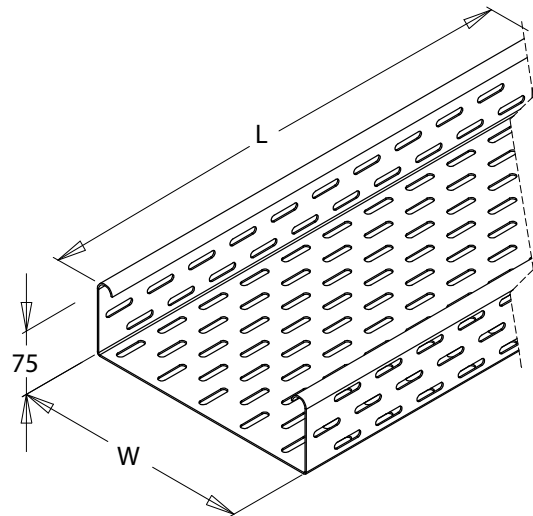
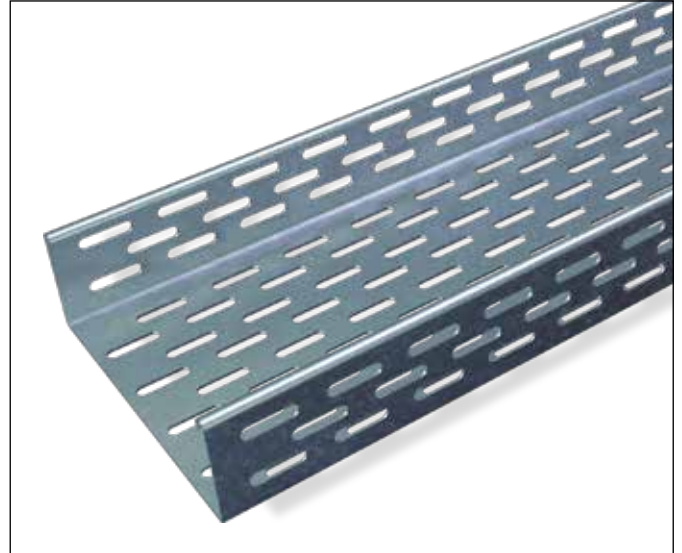

Width (mm)	Order Example				
	Item	(h)	(w)	(t)	Type
50	VCT75	075	0050	4	RFI
100	VCT75	075	0100	4	RFI

Order Example:
 VCT75 - Side height (h) - Width(w) - Thickness - Side type
 For more ordering details, please check pages 64-65

VCT - 100

Very Heavy Duty -2.00 mm Thickness

(Side Height 100 mm)

Thickness : 2.00 mm
 Side Height : 100 mm
 Length : 2440 mm / 3000 mm
 Width : 100 - 1000 mm
 Safety : 1.5

Item Code	Cable tray	Support distance (m)	Load kN/m
SVCTBS_F_00016726	VCT 100 - 100	1.00	1.50
	width (w) : 100 mm	1.20	1.50
		1.50	1.50
SVCTBS_F_00011562	VCT 150 - 100	1.00	1.50
	width (w) : 150 mm	1.20	1.50
		1.50	1.50
SVCTBS_F_00012350	VCT 200 - 100	1.00	1.50
	width (w) : 200	1.20	1.50
		1.50	1.50
SVCTBS_F_00063977	VCT 300 - 100	1.00	1.50
	width (w) : 300	1.20	1.50
		1.50	1.50
SVCTBS_F_00057035	VCT 400 - 100	1.00	1.50
	width (w) : 400	1.20	1.50
		1.50	1.50
SVCTBS_F_00183445	VCT 500 - 100	1.00	1.50
	width (w) : 500	1.20	1.50
		1.50	1.50
SVCTBS_F_00057027	VCT 600 - 100	1.00	1.50
	width (w) : 600	1.20	1.50
		1.50	1.50
SVCTBS_F_00063969	VCT 750 - 100	1.00	1.50
	width (w) : 750	1.20	1.50
		1.50	1.30
SVCTBS_F_00011838	VCT 800 - 100	0.80	1.50
	width (w) : 800	1.00	1.50
		1.20	1.20
SVCTBS_F_00011978	VCT 900 - 100	0.80	1.35
	width (w) : 900	1.00	1.35
		1.20	0.90
		1.50	0.45

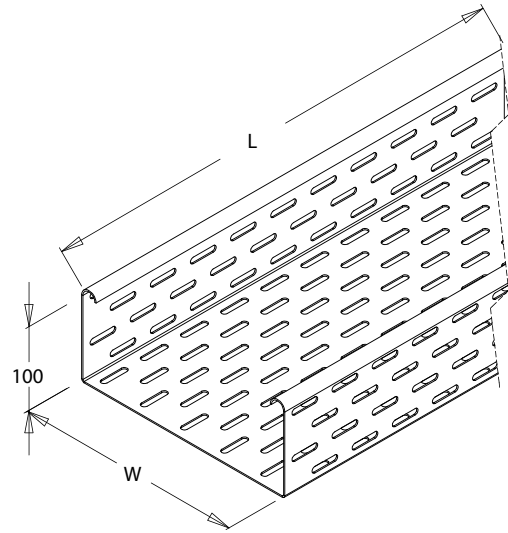
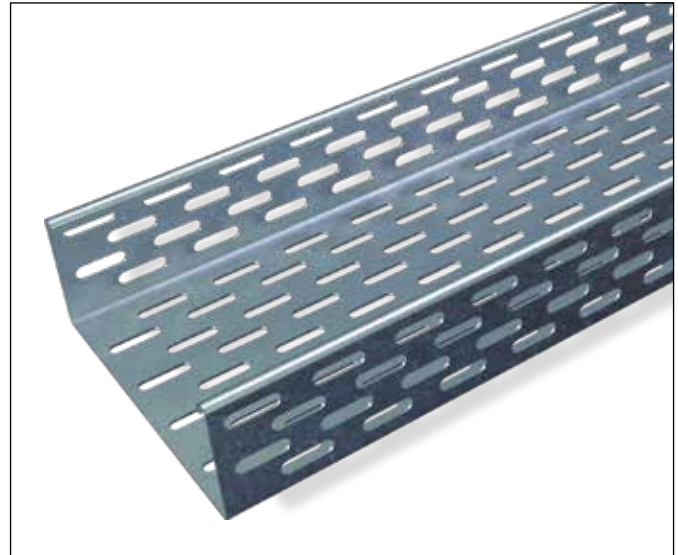

	VCT 1000 - 100	0.80	1.20
SVCTBS_F_00319408	width (w) : 1000	1.00	1.20
		1.20	1.10
		1.50	0.70

Width (mm)	Order Example				
	Item	(h)	(w)	(t)	Type
100	VCT100	0100	0050	4	RFI
150	VCT100	0100	0100	4	RFI

Order Example:
 VCT100 - Side height (h) - Width(w) - Thickness - Side type
 For more ordering details, please check pages 64-65

CABLE TRAYS FITTINGS

BEND 45°

(Side Height 50 mm)

Item Code				Cable Tray
Light Duty (LCT) 1.0mm Thickness	Medium Duty (MCT) 1.2mm Thickness	Heavy Duty (HCT) 1.5mm Thickness	Very Heavy Duty (VCT) 2.0mm Thickness	Width mm
SVCTBA_F_00054791	SVCTBA_F_00151015	SVCTBA_F_00052799	SVCTBA_F_00145077	50 - 50 width (w): 50
SVCTBA_F_00000684	SVCTBA_F_00000676	SVCTBA_F_00000668	SVCTBA_F_00000632	100 - 50 width (w): 100
SVCTBA_F_00001576	SVCTBA_F_00001552	SVCTBA_F_00001542	SVCTBA_F_00001526	150 - 50 width (w): 150
SVCTBA_F_00001626	SVCTBA_F_00148973	SVCTBA_F_00001610	SVCTBA_F_00001594	200 - 50 width (w): 200
SVCTBA_F_00001674	SVCTBA_F_00008973	SVCTBA_F_00001658	SVCTBA_F_00001642	225 - 50 width (w): 225
SVCTBA_F_00001770	SVCTBA_F_00054581	SVCTBA_F_00100893	SVCTBA_F_00001738	300 - 50 width (w): 300
	SVCTBA_F_00054891	SVCTBA_F_00089143	SVCTBA_F_00209951	400 - 50 width (w): 400
	SVCTBA_F_00062755	SVCTBA_F_00001802	SVCTBA_F_00001786	450 - 50 width (w): 450
	SVCTBA_F_00001810	SVCTBA_F_00051447	SVCTBA_F_00052313	500 - 50 width (w): 500
	SVCTBA_F_00068113	SVCTBA_F_00001850	SVCTBA_F_00001834	600 - 50 width (w): 600
		SVCTBA_F_00001890	SVCTBA_F_00001874	750 - 50 width (w): 750
			SVCTBA_F_00001906	900 - 50 width (w): 900
			SVCTBA_F_00058889	100 - 50 width (w): 1000



(Side Height 75 mm)

Item Code			Cable Tray
Medium Duty (MCT) 1.2mm Thickness	Heavy Duty (HCT) 1.5mm Thickness	Very Heavy Duty (VCT) 2.0mm Thickness	Width mm
SVCTBA_F_00248825	SVCTBA_F_00072697	SVCTBA_F_00319786	100 - 75 width (w): 100
SVCTBA_F_00248833	SVCTBA_F_00184239	SVCTBA_F_00319794	150 - 75 width (w): 150
SVCTBA_F_00319698	SVCTBA_F_00199235	SVCTBA_F_00319806	200 - 75 width (w): 200
SVCTBA_F_00233559	SVCTBA_F_00184327	SVCTBA_F_00180667	225 - 75 width (w): 225
SVCTBA_F_00248849	SVCTBA_F_00096651	SVCTBA_F_00105647	300 - 75 width (w): 300
SVCTBA_F_00260305	SVCTBA_F_00199227	SVCTBA_F_00319814	400 - 75 width (w): 400
SVCTBA_F_00319706	SVCTBA_F_00071727	SVCTBA_F_00180659	450 - 75 width (w): 450
SVCTBA_F_00319714	SVCTBA_F_00072559	SVCTBA_F_00319822	500 - 75 width (w): 500
SVCTBA_F_00319722	SVCTBA_F_00199219	SVCTBA_F_00077119	600 - 75 width (w): 600
	SVCTBA_F_00308110	SVCTBA_F_00153587	750 - 75 width (w): 750
	SVCTBA_F_00319766	SVCTBA_F_00078651	900 - 75 width (w): 900

(Side Height 100 mm)

Item Code			Cable Tray
Medium Duty (MCT) 1.2mm Thickness	Heavy Duty (HCT) 1.5mm Thickness	Very Heavy Duty (VCT) 2.0mm Thickness	Width mm
SVCTBA_F_00040270	SVCTBA_F_00095161	SVCTBA_F_00225639	100 - 100 width (w): 100
SVCTBA_F_00319902	SVCTBA_F_00095153	SVCTBA_F_00258437	150 - 100 width (w): 150
SVCTBA_F_00040278	SVCTBA_F_00120055	SVCTBA_F_00064731	200 - 100 width (w): 200
SVCTBA_F_00319918	SVCTBA_F_00117651	SVCTBA_F_00319966	225 - 100 width (w): 225
SVCTBA_F_00040286	SVCTBA_F_00080479	SVCTBA_F_00064711	300 - 100 width (w): 300
SVCTBA_F_00040294	SVCTBA_F_00080493	SVCTBA_F_00319974	400 - 100 width (w): 400
SVCTBA_F_00080845	SVCTBA_F_00186019	SVCTBA_F_00064723	450 - 100 width (w): 450
SVCTBA_F_00319926	SVCTBA_F_00042170	SVCTBA_F_00319982	500 - 100 width (w): 500
SVCTBA_F_00153737	SVCTBA_F_00040302	SVCTBA_F_00064703	600 - 100 width (w): 600
	SVCTBA_F_00276398	SVCTBA_F_00285442	750 - 100 width (w): 750
	SVCTBA_F_00271805	SVCTBA_F_00246981	900 - 100 width (w): 900
		SVCTBA_F_00319990	100 - 100 width (w): 1000

Note: Available thicknesses 1.0mm, 1.20mm, 1.50mm and 2.00mm

BEND 90°

(Side Height 50 mm)

Item Code				Cable Tray
Light Duty (LCT) 1.0mm Thickness	Medium Duty (MCT) 1.2mm Thickness	Heavy Duty (HCT) 1.5mm Thickness	Very Heavy Duty (VCT) 2.0mm Thickness	Width mm
SVCTBA_F_00054799	SVCTBA_F_00059019	SVCTBA_F_00052781	SVCTBA_F_00090905	50 - 50 width (w): 50
SVCTBA_F_00000050	SVCTBA_F_00000042	SVCTBA_F_00000034	SVCTBA_F_00175129	100 - 50 width (w): 100
SVCTBA_F_00000098	SVCTBA_F_00000090	SVCTBA_F_00000082	SVCTBA_F_00000066	150 - 50 width (w): 150
SVCTBA_F_00000154	SVCTBA_F_00213067	SVCTBA_F_00105665	SVCTBA_F_00000066	200 - 50 width (w): 200
SVCTBA_F_00000202	SVCTBA_F_00000194	SVCTBA_F_00000186	SVCTBA_F_00000170	225 - 50 width (w): 225
SVCTBA_F_00000250	SVCTBA_F_00060963	SVCTBA_F_00000234	SVCTBA_F_00000218	300 - 50 width (w): 300
	SVCTBA_F_00195401	SVCTBA_F_00051509	SVCTBA_F_00051517	400 - 50 width (w): 400
	SVCTBA_F_00000290	SVCTBA_F_00000282	SVCTBA_F_00000266	450 - 50 width (w): 450
	SVCTBA_F_00041526	SVCTBA_F_00051525	SVCTBA_F_00039670	500 - 50 width (w): 500
	SVCTBA_F_00000346	SVCTBA_F_00000338	SVCTBA_F_00000322	600 - 50 width (w): 600
		SVCTBA_F_00054469	SVCTBA_F_00000370	750 - 50 width (w): 750
		SVCTBA_F_00000418	SVCTBA_F_00000402	900 - 50 width (w): 900
		SVCTBA_F_00124605	SVCTBA_F_00058857	100 - 50 width (w): 1000



(Side Height 75 mm)

Item Code			Cable Tray
Medium Duty (MCT) 1.2mm Thickness	Heavy Duty (HCT) 1.5mm Thickness	Very Heavy Duty (VCT) 2.0mm Thickness	Width mm
SVCTBA_F_00103699	SVCTBA_F_00061707	SVCTBA_F_00320368	100 - 50 width (w): 100
SVCTBA_F_00233551	SVCTBA_F_00061699	SVCTBA_F_00105547	150 - 50 width (w): 150
SVCTBA_F_00289196	SVCTBA_F_00048396	SVCTBA_F_00320376	200 - 50 width (w): 200
SVCTBA_F_00233543	SVCTBA_F_00061683	SVCTBA_F_00114471	225 - 50 width (w): 225
SVCTBA_F_00233535	SVCTBA_F_00233527	SVCTBA_F_00105531	300 - 50 width (w): 300
SVCTBA_F_00260329	SVCTBA_F_00069521	SVCTBA_F_00292640	400 - 50 width (w): 400
SVCTBA_F_00144523	SVCTBA_F_00081579	SVCTBA_F_00061667	450 - 50 width (w): 450
SVCTBA_F_00320272	SVCTBA_F_00069529	SVCTBA_F_00292648	500 - 50 width (w): 500
SVCTBA_F_00320272	SVCTBA_F_00081595	SVCTBA_F_00077109	600 - 50 width (w): 600
SVCTBA_F_00320288	SVCTBA_F_00320344	SVCTBA_F_00153579	750 - 50 width (w): 750
	SVCTBA_F_00081605	SVCTBA_F_00172371	900 - 50 width (w): 900
	SVCTBA_F_00320360	SVCTBA_F_00320392	100 - 50 width (w): 1000

(Side Height 100 mm)

Item Code			Cable Tray
Medium Duty (MCT) 1.2mm Thickness	Heavy Duty (HCT) 1.5mm Thickness	Very Heavy Duty (VCT) 2.0mm Thickness	Width mm
SVCTBA_F_00040262	SVCTBA_F_00039546	SVCTBA_F_00120501	100 - 50 width (w): 100
SVCTBA_F_00124791	SVCTBA_F_00095145	SVCTBA_F_00284612	150 - 50 width (w): 150
SVCTBA_F_00040254	SVCTBA_F_00121945	SVCTBA_F_00100655	200 - 50 width (w): 200
SVCTBA_F_00264043	SVCTBA_F_00069513	SVCTBA_F_00276304	225 - 50 width (w): 225
SVCTBA_F_00040246	SVCTBA_F_00041974	SVCTBA_F_00147867	300 - 50 width (w): 300
SVCTBA_F_00040238	SVCTBA_F_00090563	SVCTBA_F_00111609	400 - 50 width (w): 400
SVCTBA_F_00080853	SVCTBA_F_00039514	SVCTBA_F_00064671	450 - 50 width (w): 450
SVCTBA_F_00240463	SVCTBA_F_00041518	SVCTBA_F_00237633	500 - 50 width (w): 500
SVCTBA_F_00163335	SVCTBA_F_00041506	SVCTBA_F_00064663	600 - 50 width (w): 600
	SVCTBA_F_00219319	SVCTBA_F_00112711	750 - 50 width (w): 750
	SVCTBA_F_00089843	SVCTBA_F_00064893	900 - 50 width (w): 900
	SVCTBA_F_00320576	SVCTBA_F_00121215	100 - 50 width (w): 1000

Note: Available thicknesses 1.0mm, 1.20mm, 1.50mm and 2.00mm

TEE BRANCH

(Side Height 50 mm)

Item Code				Cable Tray
Light Duty (LCT) 1.0mm Thickness	Medium Duty (MCT) 1.2mm Thickness	Heavy Duty (HCT) 1.5mm Thickness	Very Heavy Duty (VCT) 2.0mm Thickness	Width mm
SVCTBA_F_00079915	SVCTBA_F_00059011	SVCTBA_F_00105427	SVCTBA_F_00090465	50 - 50 width (w): 50
SVCTBA_F_00019694	SVCTBA_F_00019686	SVCTBA_F_00019678	SVCTBA_F_00019662	100 - 50 width (w): 100
SVCTBA_F_00019742	SVCTBA_F_00019734	SVCTBA_F_00043436	SVCTBA_F_00019710	150 - 50 width (w): 150
SVCTBA_F_00019790	SVCTBA_F_00019782	SVCTBA_F_00043340	SVCTBA_F_00019758	200 - 50 width (w): 200
SVCTBA_F_00019838	SVCTBA_F_00067321	SVCTBA_F_00019822	SVCTBA_F_00019806	225 - 50 width (w): 225
SVCTBA_F_00019886	SVCTBA_F_00019878	SVCTBA_F_00019870	SVCTBA_F_00019854	300 - 50 width (w): 300
	SVCTBA_F_00062763	SVCTBA_F_00057539	SVCTBA_F_00200645	400 - 50 width (w): 400
	SVCTBA_F_00019918	SVCTBA_F_00019910	SVCTBA_F_00019894	450 - 50 width (w): 450
	SVCTBA_F_00320024	SVCTBA_F_00050967	SVCTBA_F_00200517	500 - 50 width (w): 500
	SVCTBA_F_00019966	SVCTBA_F_00019958	SVCTBA_F_00019942	600 - 50 width (w): 600
		SVCTBA_F_00020006	SVCTBA_F_00019990	750 - 50 width (w): 750
			SVCTBA_F_00020038	900 - 50 width (w): 900
			SVCTBA_F_00058897	100 - 50 width (w): 1000



(Side Height 75 mm)

Item Code			Cable Tray
Medium Duty (MCT) 1.2mm Thickness	Heavy Duty (HCT) 1.5mm Thickness	Very Heavy Duty (VCT) 2.0mm Thickness	Width mm
SVCTBA_F_00172069	SVCTBA_F_00061635	SVCTBA_F_00320634	100 - 50 width (w): 100
SVCTBA_F_00233519	SVCTBA_F_00061651	SVCTBA_F_00105539	150 - 50 width (w): 150
SVCTBA_F_00320424	SVCTBA_F_00048420	SVCTBA_F_00292664	200 - 50 width (w): 200
SVCTBA_F_00228765	SVCTBA_F_00061643	SVCTBA_F_00180763	225 - 50 width (w): 225
SVCTBA_F_00228773	SVCTBA_F_00061627	SVCTBA_F_00180755	300 - 50 width (w): 300
SVCTBA_F_00320810	SVCTBA_F_00069159	SVCTBA_F_00292672	400 - 50 width (w): 400
SVCTBA_F_00144595	SVCTBA_F_00081587	SVCTBA_F_00061619	450 - 50 width (w): 450
SVCTBA_F_00320448	SVCTBA_F_00096563	SVCTBA_F_00292680	500 - 50 width (w): 500
SVCTBA_F_00320448	SVCTBA_F_00081549	SVCTBA_F_00078659	600 - 50 width (w): 600
SVCTBA_F_00320504	SVCTBA_F_00320584	SVCTBA_F_00180747	750 - 50 width (w): 750
	SVCTBA_F_00081615	SVCTBA_F_00129119	900 - 50 width (w): 900
	SVCTBA_F_00320604	SVCTBA_F_00320642	100 - 50 width (w): 1000

(Side Height 100 mm)

Item Code			Cable Tray
Medium Duty (MCT) 1.2mm Thickness	Heavy Duty (HCT) 1.5mm Thickness	Very Heavy Duty (VCT) 2.0mm Thickness	Width mm
SVCTBA_F_00040318	SVCTBA_F_00039554	SVCTBA_F_00225879	100 - 50 width (w): 100
SVCTBA_F_00181729	SVCTBA_F_00095843	SVCTBA_F_00258477	150 - 50 width (w): 150
SVCTBA_F_00040358	SVCTBA_F_00039562	SVCTBA_F_00320658	200 - 50 width (w): 200
SVCTBA_F_00184825	SVCTBA_F_00072753	SVCTBA_F_00320858	225 - 50 width (w): 225
SVCTBA_F_00040350	SVCTBA_F_00073695	SVCTBA_F_00147875	300 - 50 width (w): 300
SVCTBA_F_00040342	SVCTBA_F_00303366	SVCTBA_F_0011827	400 - 50 width (w): 400
SVCTBA_F_00080837	SVCTBA_F_00050959	SVCTBA_F_00242381	450 - 50 width (w): 450
SVCTBA_F_00097231	SVCTBA_F_00092385	SVCTBA_F_00320682	500 - 50 width (w): 500
SVCTBA_F_00153721	SVCTBA_F_00040366	SVCTBA_F_00064879	600 - 50 width (w): 600
	SVCTBA_F_00320614	SVCTBA_F_00207695	750 - 50 width (w): 750
	SVCTBA_F_00167125	SVCTBA_F_00095121	900 - 50 width (w): 900
	SVCTBA_F_00320624	SVCTBA_F_00320714	100 - 50 width (w): 1000

Note: Available thicknesses 1.0mm, 1.20mm, 1.50mm and 2.00mm

INTERSECTION

(Side Height 50 mm)

Item Code				Cable Tray
Light Duty (LCT) 1.0mm Thickness	Medium Duty (MCT) 1.2mm Thickness	Heavy Duty (HCT) 1.5mm Thickness	Very Heavy Duty (VCT) 2.0mm Thickness	Width mm
SVCTBA_F_00320650	SVCTBA_F_00151023	SVCTBA_F_00321082	SVCTBA_F_00321122	50 - 50 width (w): 50
SVCTBA_F_00320666	SVCTBA_F_00109145	SVCTBA_F_00072245	SVCTBA_F_00220793	100 - 50 width (w): 100
SVCTBA_F_00126007	SVCTBA_F_00100647	SVCTBA_F_00066747	SVCTBA_F_00114599	150 - 50 width (w): 150
SVCTBA_F_00254523	SVCTBA_F_00287828	SVCTBA_F_00060083	SVCTBA_F_00244141	200 - 50 width (w): 200
SVCTBA_F_00072189	SVCTBA_F_00148747	SVCTBA_F_00072229	SVCTBA_F_00090441	225 - 50 width (w): 225
SVCTBA_F_00320674	SVCTBA_F_00059603	SVCTBA_F_00074211	SVCTBA_F_00114591	300 - 50 width (w): 300
	SVCTBA_F_00254531	SVCTBA_F_00210089	SVCTBA_F_00321138	400 - 50 width (w): 400
	SVCTBA_F_00313974	SVCTBA_F_00132011	SVCTBA_F_00114583	450 - 50 width (w): 450
	SVCTBA_F_00321034	SVCTBA_F_00212281	SVCTBA_F_00321146	500 - 50 width (w): 500
	SVCTBA_F_00249611	SVCTBA_F_00052597	SVCTBA_F_00100325	600 - 50 width (w): 600
		SVCTBA_F_00267565	SVCTBA_F_00138087	750 - 50 width (w): 750
		SVCTBA_F_00244033	SVCTBA_F_00142481	900 - 50 width (w): 900
		SVCTBA_F_00321114	SVCTBA_F_00321162	100 - 50 width (w): 1000

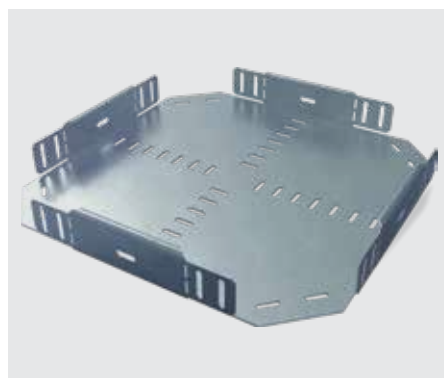

(Side Height 75 mm)

Item Code			Cable Tray
Medium Duty (MCT) 1.2mm Thickness	Heavy Duty (HCT) 1.5mm Thickness	Very Heavy Duty (VCT) 2.0mm Thickness	Width mm
SVCTBA_F_00321330	SVCTBA_F_00210221	SVCTBA_F_00321490	100 - 50 width (w): 100
SVCTBA_F_00321346	SVCTBA_F_00184295	SVCTBA_F_00321506	150 - 50 width (w): 150
SVCTBA_F_00321354	SVCTBA_F_00210229	SVCTBA_F_00321514	200 - 50 width (w): 200
SVCTBA_F_00321362	SVCTBA_F_00184351	SVCTBA_F_00321530	225 - 50 width (w): 225
SVCTBA_F_00321370	SVCTBA_F_00184287	SVCTBA_F_00321538	300 - 50 width (w): 300
SVCTBA_F_00321378	SVCTBA_F_00210237	SVCTBA_F_00321546	400 - 50 width (w): 400
SVCTBA_F_00321402	SVCTBA_F_00210245	SVCTBA_F_00184279	450 - 50 width (w): 450
SVCTBA_F_00321410	SVCTBA_F_00096857	SVCTBA_F_00321554	500 - 50 width (w): 500
SVCTBA_F_00321418	SVCTBA_F_00212297	SVCTBA_F_00321562	600 - 50 width (w): 600
SVCTBA_F_00321426	SVCTBA_F_00321458	SVCTBA_F_00184271	750 - 50 width (w): 750
	SVCTBA_F_00321474	SVCTBA_F_00184263	900 - 50 width (w): 900
	SVCTBA_F_00321482	SVCTBA_F_00321570	100 - 50 width (w): 1000

(Side Height 100 mm)

Item Code			Cable Tray
Medium Duty (MCT) 1.2mm Thickness	Heavy Duty (HCT) 1.5mm Thickness	Very Heavy Duty (VCT) 2.0mm Thickness	Width mm
SVCTBA_F_00055435	SVCTBA_F_00210253	SVCTBA_F_00321874	100 - 50 width (w): 100
SVCTBA_F_00303296	SVCTBA_F_00210261	SVCTBA_F_00321882	150 - 50 width (w): 150
SVCTBA_F_00101011	SVCTBA_F_00210269	SVCTBA_F_00321896	200 - 50 width (w): 200
SVCTBA_F_00321746	SVCTBA_F_00210277	SVCTBA_F_00321906	225 - 50 width (w): 225
SVCTBA_F_00216689	SVCTBA_F_00210285	SVCTBA_F_00168317	300 - 50 width (w): 300
SVCTBA_F_00303304	SVCTBA_F_00210293	SVCTBA_F_00212695	400 - 50 width (w): 400
SVCTBA_F_00321754	SVCTBA_F_00210301	SVCTBA_F_00242389	450 - 50 width (w): 450
SVCTBA_F_00321770	SVCTBA_F_00178389	SVCTBA_F_00321916	500 - 50 width (w): 500
SVCTBA_F_00321778	SVCTBA_F_00101825	SVCTBA_F_00095137	600 - 50 width (w): 600
	SVCTBA_F_00321834	SVCTBA_F_00321930	750 - 50 width (w): 750
	SVCTBA_F_00321842	SVCTBA_F_00095129	900 - 50 width (w): 900
	SVCTBA_F_00321852	SVCTBA_F_00321938	100 - 50 width (w): 1000

Note: Available thicknesses 1.0mm, 1.20mm, 1.50mm and 2.00mm

OUTSIDE RISER BEND 45°

(Side Height 50 mm)

Item Code				Cable Tray
Light Duty (LCT) 1.0mm Thickness	Medium Duty (MCT) 1.2mm Thickness	Heavy Duty (HCT) 1.5mm Thickness	Very Heavy Duty (VCT) 2.0mm Thickness	Width mm
SVCTBA_F_00284462	SVCTBA_F_00291194	SVCTBA_F_00196339	SVCTBA_F_00145091	50 - 50 width (w): 50
SVCTBA_F_00016934	SVCTBA_F_00016926	SVCTBA_F_00016910	SVCTBA_F_00016894	100 - 50 width (w): 100
SVCTBA_F_00016838	SVCTBA_F_00016830	SVCTBA_F_00016814	SVCTBA_F_00016798	150 - 50 width (w): 150
SVCTBA_F_00016766	SVCTBA_F_00016758	SVCTBA_F_00016750	SVCTBA_F_00016734	200 - 50 width (w): 200
SVCTBA_F_00016562	SVCTBA_F_00016550	SVCTBA_F_00016534	SVCTBA_F_00016478	225 - 50 width (w): 225
SVCTBA_F_00016444	SVCTBA_F_00016406	SVCTBA_F_00016398	SVCTBA_F_00016382	300 - 50 width (w): 300
	SVCTBA_F_00151203	SVCTBA_F_00210309	SVCTBA_F_00321498	400 - 50 width (w): 400
	SVCTBA_F_00016358	SVCTBA_F_00016350	SVCTBA_F_00016334	450 - 50 width (w): 450
	SVCTBA_F_00320946	SVCTBA_F_00212321	SVCTBA_F_00321522	500 - 50 width (w): 500
	SVCTBA_F_00016278	SVCTBA_F_00016270	SVCTBA_F_00016254	600 - 50 width (w): 600
		SVCTBA_F_00016230	SVCTBA_F_00016214	750 - 50 width (w): 750
		SVCTBA_F_00016190	SVCTBA_F_00016166	900 - 50 width (w): 900
		SVCTBA_F_00321338	SVCTBA_F_00292430	100 - 50 width (w): 1000



(Side Height 75 mm)

Item Code			Cable Tray
Medium Duty (MCT) 1.2mm Thickness	Heavy Duty (HCT) 1.5mm Thickness	Very Heavy Duty (VCT) 2.0mm Thickness	Width mm
SVCTBA_F_00320962	SVCTBA_F_00210317	SVCTBA_F_00321738	100 - 50 width (w): 100
SVCTBA_F_00320970	SVCTBA_F_00210325	SVCTBA_F_00321762	150 - 50 width (w): 150
SVCTBA_F_00320978	SVCTBA_F_00210333	SVCTBA_F_00321794	200 - 50 width (w): 200
SVCTBA_F_00321970	SVCTBA_F_00210341	SVCTBA_F_00321818	225 - 50 width (w): 225
SVCTBA_F_00321018	SVCTBA_F_00210349	SVCTBA_F_00321826	300 - 50 width (w): 300
SVCTBA_F_00321026	SVCTBA_F_00210357	SVCTBA_F_00321850	400 - 50 width (w): 400
SVCTBA_F_00321978	SVCTBA_F_00210365	SVCTBA_F_00321986	450 - 50 width (w): 450
SVCTBA_F_00321058	SVCTBA_F_00212337	SVCTBA_F_00321866	500 - 50 width (w): 500
SVCTBA_F_00321074	SVCTBA_F_00212345	SVCTBA_F_00321890	600 - 50 width (w): 600
SVCTBA_F_00321090	SVCTBA_F_00095449	SVCTBA_F_00321914	750 - 50 width (w): 750
	SVCTBA_F_00321386	SVCTBA_F_00321946	900 - 50 width (w): 900
	SVCTBA_F_00321394	SVCTBA_F_00321954	100 - 50 width (w): 1000

(Side Height 100 mm)

Item Code			Cable Tray
Medium Duty (MCT) 1.2mm Thickness	Heavy Duty (HCT) 1.5mm Thickness	Very Heavy Duty (VCT) 2.0mm Thickness	Width mm
SVCTBA_F_00321130	SVCTBA_F_00198011	SVCTBA_F_00225727	100 - 50 width (w): 100
SVCTBA_F_00321154	SVCTBA_F_00210373	SVCTBA_F_00321578	150 - 50 width (w): 150
SVCTBA_F_00321170	SVCTBA_F_00120143	SVCTBA_F_00321586	200 - 50 width (w): 200
SVCTBA_F_00322010	SVCTBA_F_00210381	SVCTBA_F_00322018	225 - 50 width (w): 225
SVCTBA_F_00321178	SVCTBA_F_00120151	SVCTBA_F_00321610	300 - 50 width (w): 300
SVCTBA_F_00321202	SVCTBA_F_00120159	SVCTBA_F_00321636	400 - 50 width (w): 400
SVCTBA_F_00322002	SVCTBA_F_00124807	SVCTBA_F_00251089	450 - 50 width (w): 450
SVCTBA_F_00320786	SVCTBA_F_00212361	SVCTBA_F_00321658	500 - 50 width (w): 500
SVCTBA_F_00321242	SVCTBA_F_00212369	SVCTBA_F_00321674	600 - 50 width (w): 600
	SVCTBA_F_00321450	SVCTBA_F_00321690	750 - 50 width (w): 750
	SVCTBA_F_00116631	SVCTBA_F_00321706	900 - 50 width (w): 900
	SVCTBA_F_00321460	SVCTBA_F_00321730	100 - 50 width (w): 1000

Note: Available thicknesses 1.0mm, 1.20mm, 1.50mm and 2.00mm

INSIDE RISER 45°

(Side Height 50 mm)

Item Code				Cable Tray
Light Duty (LCT) 1.0mm Thickness	Medium Duty (MCT) 1.2mm Thickness	Heavy Duty (HCT) 1.5mm Thickness	Very Heavy Duty (VCT) 2.0mm Thickness	Width mm
SVCTBA_F_00284470	SVCTBA_F_00265991	SVCTBA_F_00196331	SVCTBA_F_00145107	50 - 50 width (w): 50
SVCTBA_F_00015102	SVCTBA_F_00015094	SVCTBA_F_00015086	SVCTBA_F_00015070	100 - 50 width (w): 100
SVCTBA_F_00015046	SVCTBA_F_00015038	SVCTBA_F_00015030	SVCTBA_F_00015014	150 - 50 width (w): 150
SVCTBA_F_00014998	SVCTBA_F_00014990	SVCTBA_F_00014982	SVCTBA_F_00014966	200 - 50 width (w): 200
SVCTBA_F_00014950	SVCTBA_F_00014942	SVCTBA_F_00014934	SVCTBA_F_00175723	225 - 50 width (w): 225
SVCTBA_F_00014902	SVCTBA_F_00014894	SVCTBA_F_00014886	SVCTBA_F_00014870	300 - 50 width (w): 300
	SVCTBA_F_00151211	SVCTBA_F_00210389	SVCTBA_F_00323362	400 - 50 width (w): 400
	SVCTBA_F_00014846	SVCTBA_F_00014838	SVCTBA_F_00014822	450 - 50 width (w): 450
	SVCTBA_F_00068121	SVCTBA_F_00212385	SVCTBA_F_00323370	500 - 50 width (w): 500
	SVCTBA_F_00014806	SVCTBA_F_00014798	SVCTBA_F_00014782	600 - 50 width (w): 600
		SVCTBA_F_00014758	SVCTBA_F_00014742	750 - 50 width (w): 750
		SVCTBA_F_00014726	SVCTBA_F_00014710	900 - 50 width (w): 900
		SVCTBA_F_00323354	SVCTBA_F_00292420	100 - 50 width (w): 1000



(Side Height 75 mm)

Item Code			Cable Tray
Medium Duty (MCT) 1.2mm Thickness	Heavy Duty (HCT) 1.5mm Thickness	Very Heavy Duty (VCT) 2.0mm Thickness	Width mm
SVCTBA_F_00323522	SVCTBA_F_00210397	SVCTBA_F_00323634	100 - 50 width (w): 100
SVCTBA_F_00323530	SVCTBA_F_00210405	SVCTBA_F_00323642	150 - 50 width (w): 150
SVCTBA_F_00323538	SVCTBA_F_00210413	SVCTBA_F_00323650	200 - 50 width (w): 200
SVCTBA_F_00323546	SVCTBA_F_00210421	SVCTBA_F_00323658	225 - 50 width (w): 225
SVCTBA_F_00323554	SVCTBA_F_00210429	SVCTBA_F_00323666	300 - 50 width (w): 300
SVCTBA_F_00323562	SVCTBA_F_00210437	SVCTBA_F_00323674	400 - 50 width (w): 400
SVCTBA_F_00323570	SVCTBA_F_00210445	SVCTBA_F_00323682	450 - 50 width (w): 450
SVCTBA_F_00323578	SVCTBA_F_00212401	SVCTBA_F_00323690	500 - 50 width (w): 500
SVCTBA_F_00323586	SVCTBA_F_00212409	SVCTBA_F_00323698	600 - 50 width (w): 600
SVCTBA_F_00323594	SVCTBA_F_00308238	SVCTBA_F_00323706	750 - 50 width (w): 750
	SVCTBA_F_00323618	SVCTBA_F_00323714	900 - 50 width (w): 900
	SVCTBA_F_00323626	SVCTBA_F_00323722	100 - 50 width (w): 1000

(Side Height 100 mm)

Item Code			Cable Tray
Medium Duty (MCT) 1.2mm Thickness	Heavy Duty (HCT) 1.5mm Thickness	Very Heavy Duty (VCT) 2.0mm Thickness	Width mm
SVCTBA_F_00324648	SVCTBA_F_00120101	SVCTBA_F_00225735	100 - 50 width (w): 100
SVCTBA_F_00324656	SVCTBA_F_00210453	SVCTBA_F_00324744	150 - 50 width (w): 150
SVCTBA_F_00324664	SVCTBA_F_00120111	SVCTBA_F_00324752	200 - 50 width (w): 200
SVCTBA_F_00324672	SVCTBA_F_00210461	SVCTBA_F_00324768	225 - 50 width (w): 225
SVCTBA_F_00318454	SVCTBA_F_00120119	SVCTBA_F_00324776	300 - 50 width (w): 300
SVCTBA_F_00324680	SVCTBA_F_00210469	SVCTBA_F_00324790	400 - 50 width (w): 400
SVCTBA_F_00080797	SVCTBA_F_00124799	SVCTBA_F_00251081	450 - 50 width (w): 450
SVCTBA_F_00324688	SVCTBA_F_00212425	SVCTBA_F_00324800	500 - 50 width (w): 500
SVCTBA_F_00318446	SVCTBA_F_00212433	SVCTBA_F_00324810	600 - 50 width (w): 600
	SVCTBA_F_00324720	SVCTBA_F_00324818	750 - 50 width (w): 750
	SVCTBA_F_00324728	SVCTBA_F_00324826	900 - 50 width (w): 900
	SVCTBA_F_00324736	SVCTBA_F_00324834	100 - 50 width (w): 1000

Note: Available thicknesses 1.0mm, 1.20mm, 1.50mm and 2.00mm

OUTSIDE RISER BEND 90°

(Side Height 50 mm)

Item Code				Cable Tray
Light Duty (LCT) 1.0mm Thickness	Medium Duty (MCT) 1.2mm Thickness	Heavy Duty (HCT) 1.5mm Thickness	Very Heavy Duty (VCT) 2.0mm Thickness	Width mm
SVCTBA_F_00054783	SVCTBA_F_00119167	SVCTBA_F_00116615	SVCTBA_F_00111747	50 - 50 width (w): 50
SVCTBA_F_00019262	SVCTBA_F_00019254	SVCTBA_F_00019246	SVCTBA_F_00019230	100 - 50 width (w): 100
SVCTBA_F_00019310	SVCTBA_F_00019302	SVCTBA_F_00136215	SVCTBA_F_00019278	150 - 50 width (w): 150
SVCTBA_F_00019358	SVCTBA_F_00019350	SVCTBA_F_00019342	SVCTBA_F_00019326	200 - 50 width (w): 200
SVCTBA_F_00019598	SVCTBA_F_00019590	SVCTBA_F_00019582	SVCTBA_F_00019566	225 - 50 width (w): 225
SVCTBA_F_00019646	SVCTBA_F_00019638	SVCTBA_F_00136223	SVCTBA_F_00019614	300 - 50 width (w): 300
	SVCTBA_F_00151187	SVCTBA_F_00099123	SVCTBA_F_00120453	400 - 50 width (w): 400
	SVCTBA_F_00019398	SVCTBA_F_00019390	SVCTBA_F_00019374	450 - 50 width (w): 450
	SVCTBA_F_00311004	SVCTBA_F_00051617	SVCTBA_F_00058931	500 - 50 width (w): 500
	SVCTBA_F_00019438	SVCTBA_F_00019430	SVCTBA_F_00019414	600 - 50 width (w): 600
		SVCTBA_F_00019486	SVCTBA_F_00019470	750 - 50 width (w): 750
			SVCTBA_F_00019502	900 - 50 width (w): 900
			SVCTBA_F_00062581	100 - 50 width (w): 1000



(Side Height 75 mm)

Item Code			Cable Tray
Medium Duty (MCT) 1.2mm Thickness	Heavy Duty (HCT) 1.5mm Thickness	Very Heavy Duty (VCT) 2.0mm Thickness	Width mm
SVCTBA_F_00248891	SVCTBA_F_00072829	SVCTBA_F_00211311	100 - 50 width (w): 100
SVCTBA_F_00268785	SVCTBA_F_00184255	SVCTBA_F_00292848	150 - 50 width (w): 150
SVCTBA_F_00305504	SVCTBA_F_00072837	SVCTBA_F_00292856	200 - 50 width (w): 200
SVCTBA_F_00250153	SVCTBA_F_00184343	SVCTBA_F_00180739	225 - 50 width (w): 225
SVCTBA_F_00250161	SVCTBA_F_00051549	SVCTBA_F_00292864	300 - 50 width (w): 300
SVCTBA_F_00260409	SVCTBA_F_00072845	SVCTBA_F_00292872	400 - 50 width (w): 400
SVCTBA_F_00322696	SVCTBA_F_00210477	SVCTBA_F_00105639	450 - 50 width (w): 450
SVCTBA_F_00322704	SVCTBA_F_00072853	SVCTBA_F_00292880	500 - 50 width (w): 500
SVCTBA_F_00322712	SVCTBA_F_00212449	SVCTBA_F_00292888	600 - 50 width (w): 600
SVCTBA_F_00322720	SVCTBA_F_00322786	SVCTBA_F_00292896	750 - 50 width (w): 750
	SVCTBA_F_00322794	SVCTBA_F_00180715	900 - 50 width (w): 900
	SVCTBA_F_00322802	SVCTBA_F_00322818	100 - 50 width (w): 1000

(Side Height 100 mm)

Item Code			Cable Tray
Medium Duty (MCT) 1.2mm Thickness	Heavy Duty (HCT) 1.5mm Thickness	Very Heavy Duty (VCT) 2.0mm Thickness	Width mm
SVCTBA_F_00102007	SVCTBA_F_00074057	SVCTBA_F_00225711	100 - 50 width (w): 100
SVCTBA_F_00322744	SVCTBA_F_00095995	SVCTBA_F_00258469	150 - 50 width (w): 150
SVCTBA_F_00263143	SVCTBA_F_00148059	SVCTBA_F_00322826	200 - 50 width (w): 200
SVCTBA_F_00323116	SVCTBA_F_00112657	SVCTBA_F_00322834	225 - 50 width (w): 225
SVCTBA_F_00090481	SVCTBA_F_00072439	SVCTBA_F_00258517	300 - 50 width (w): 300
SVCTBA_F_00322754	SVCTBA_F_00231893	SVCTBA_F_00111675	400 - 50 width (w): 400
SVCTBA_F_00080813	SVCTBA_F_00242397	SVCTBA_F_00258525	450 - 50 width (w): 450
SVCTBA_F_00097239	SVCTBA_F_00092393	SVCTBA_F_00322842	500 - 50 width (w): 500
SVCTBA_F_00271361	SVCTBA_F_00042184	SVCTBA_F_00095207	600 - 50 width (w): 600
	SVCTBA_F_00272527	SVCTBA_F_00215207	750 - 50 width (w): 750
	SVCTBA_F_00101999	SVCTBA_F_00095199	900 - 50 width (w): 900
	SVCTBA_F_00322810	SVCTBA_F_00322850	100 - 50 width (w): 1000

Note: Available thicknesses 1.0mm, 1.20mm, 1.50mm and 2.00mm

INSIDE RISER BEND 90°

(Side Height 50 mm)

Item Code				Cable Tray
Light Duty (LCT) 1.0mm Thickness	Medium Duty (MCT) 1.2mm Thickness	Heavy Duty (HCT) 1.5mm Thickness	Very Heavy Duty (VCT) 2.0mm Thickness	Width mm
SVCTBA_F_00054775	SVCTBA_F_00046062	SVCTBA_F_00323266	SVCTBA_F_0011811	50 - 50 width (w): 50
SVCTBA_F_00018590	SVCTBA_F_00018580	SVCTBA_F_00323274	SVCTBA_F_00018544	100 - 50 width (w): 100
SVCTBA_F_00018654	SVCTBA_F_00018646	SVCTBA_F_00018638	SVCTBA_F_00018622	150 - 50 width (w): 150
SVCTBA_F_00018766	SVCTBA_F_00018746	SVCTBA_F_00018734	SVCTBA_F_00018686	200 - 50 width (w): 200
SVCTBA_F_00018820	SVCTBA_F_00018810	SVCTBA_F_00018800	SVCTBA_F_00018782	225 - 50 width (w): 225
SVCTBA_F_00018894	SVCTBA_F_00018886	SVCTBA_F_00288422	SVCTBA_F_00018838	300 - 50 width (w): 300
	SVCTBA_F_00151195	SVCTBA_F_00099105	SVCTBA_F_00176693	400 - 50 width (w): 400
	SVCTBA_F_00019174	SVCTBA_F_00218621	SVCTBA_F_00019070	450 - 50 width (w): 450
	SVCTBA_F_00311012	SVCTBA_F_00129091	SVCTBA_F_00058923	500 - 50 width (w): 500
	SVCTBA_F_00019158	SVCTBA_F_00019140	SVCTBA_F_00019118	600 - 50 width (w): 600
		SVCTBA_F_00019198	SVCTBA_F_00019182	750 - 50 width (w): 750
			SVCTBA_F_00019214	900 - 50 width (w): 900
			SVCTBA_F_00107433	100 - 50 width (w): 1000



(Side Height 75 mm)

Item Code			Cable Tray
Medium Duty (MCT) 1.2mm Thickness	Heavy Duty (HCT) 1.5mm Thickness	Very Heavy Duty (VCT) 2.0mm Thickness	Width mm
SVCTBA_F_00250169	SVCTBA_F_00072861	SVCTBA_F_00292784	100 - 50 width (w): 100
SVCTBA_F_00250177	SVCTBA_F_00184247	SVCTBA_F_00292792	150 - 50 width (w): 150
SVCTBA_F_00323148	SVCTBA_F_00210493	SVCTBA_F_00292800	200 - 50 width (w): 200
SVCTBA_F_00250185	SVCTBA_F_00184335	SVCTBA_F_00180707	225 - 50 width (w): 225
SVCTBA_F_00250193	SVCTBA_F_00072869	SVCTBA_F_00180699	300 - 50 width (w): 300
SVCTBA_F_00260385	SVCTBA_F_00072877	SVCTBA_F_00292808	400 - 50 width (w): 400
SVCTBA_F_00323156	SVCTBA_F_00190217	SVCTBA_F_00132479	450 - 50 width (w): 450
SVCTBA_F_00323164	SVCTBA_F_00072885	SVCTBA_F_00292816	500 - 50 width (w): 500
SVCTBA_F_00323172	SVCTBA_F_00072893	SVCTBA_F_00292824	600 - 50 width (w): 600
SVCTBA_F_00323180	SVCTBA_F_00323282	SVCTBA_F_00292832	750 - 50 width (w): 750
	SVCTBA_F_00323290	SVCTBA_F_00180675	900 - 50 width (w): 900
	SVCTBA_F_00323298	SVCTBA_F_00323378	100 - 50 width (w): 1000

(Side Height 100 mm)

Item Code			Cable Tray
Medium Duty (MCT) 1.2mm Thickness	Heavy Duty (HCT) 1.5mm Thickness	Very Heavy Duty (VCT) 2.0mm Thickness	Width mm
SVCTBA_F_00323204	SVCTBA_F_00136179	SVCTBA_F_00225719	100 - 50 width (w): 100
SVCTBA_F_00323212	SVCTBA_F_00136189	SVCTBA_F_00258461	150 - 50 width (w): 150
SVCTBA_F_00081245	SVCTBA_F_00210501	SVCTBA_F_00323394	200 - 50 width (w): 200
SVCTBA_F_00096529	SVCTBA_F_00072729	SVCTBA_F_00323426	225 - 50 width (w): 225
SVCTBA_F_00067733	SVCTBA_F_00042008	SVCTBA_F_00258509	300 - 50 width (w): 300
SVCTBA_F_00323226	SVCTBA_F_00210509	SVCTBA_F_0011763	400 - 50 width (w): 400
SVCTBA_F_00080829	SVCTBA_F_00042016	SVCTBA_F_00147179	450 - 50 width (w): 450
SVCTBA_F_00323234	SVCTBA_F_00212489	SVCTBA_F_00323458	500 - 50 width (w): 500
SVCTBA_F_00271319	SVCTBA_F_00043836	SVCTBA_F_00095191	600 - 50 width (w): 600
	SVCTBA_F_00295286	SVCTBA_F_00323482	750 - 50 width (w): 750
	SVCTBA_F_00091589	SVCTBA_F_00095183	900 - 50 width (w): 900
		SVCTBA_F_00323514	100 - 50 width (w): 1000

Note: Available thicknesses 1.0mm, 1.20mm, 1.50mm and 2.00mm

REDUCER

(Side Height 25 mm)

Medium Duty (MCT) 1.2mm Thickness	Item Code			Cable Tray
	Medium Duty (MCT) 1.2mm Thickness	Heavy Duty (HCT) 1.5mm Thickness	Very Heavy Duty (VCT) 2.0mm Thickness	Width mm
SVCTBA_F_00324296	SVCTBA_F_00325104	SVCTBA_F_00326440	SVCTBA_F_00326912	100 - 50
SVCTBA_F_00324304	SVCTBA_F_00325112	SVCTBA_F_00326448	SVCTBA_F_00326920	150 - 50
SVCTBA_F_00324312	SVCTBA_F_00325120	SVCTBA_F_00326456	SVCTBA_F_00326928	150 - 100
SVCTBA_F_00324272	SVCTBA_F_00325080	SVCTBA_F_00326416	SVCTBA_F_00326888	200 - 50
SVCTBA_F_00324280	SVCTBA_F_00325088	SVCTBA_F_00326424	SVCTBA_F_00326896	200 - 100
SVCTBA_F_00324288	SVCTBA_F_00325096	SVCTBA_F_00326432	SVCTBA_F_00326904	200 - 150
SVCTBA_F_00324240	SVCTBA_F_00325048	SVCTBA_F_00326384	SVCTBA_F_00326856	225 - 50
SVCTBA_F_00324248	SVCTBA_F_00325056	SVCTBA_F_00326392	SVCTBA_F_00326864	225 - 100
SVCTBA_F_00324256	SVCTBA_F_00325064	SVCTBA_F_00326400	SVCTBA_F_00326872	225 - 150
SVCTBA_F_00324264	SVCTBA_F_00325072	SVCTBA_F_00326408	SVCTBA_F_00326880	225 - 200
SVCTBA_F_00324194	SVCTBA_F_00325008	SVCTBA_F_00326344	SVCTBA_F_00326816	300 - 50
SVCTBA_F_00324208	SVCTBA_F_00325016	SVCTBA_F_00326352	SVCTBA_F_00326824	300 - 100
SVCTBA_F_00324216	SVCTBA_F_00325024	SVCTBA_F_00326360	SVCTBA_F_00326832	300 - 150
SVCTBA_F_00324224	SVCTBA_F_00325032	SVCTBA_F_00326368	SVCTBA_F_00326840	300 - 200
SVCTBA_F_00324232	SVCTBA_F_00325040	SVCTBA_F_00326376	SVCTBA_F_00326848	300 - 225
SVCTBA_F_00324146	SVCTBA_F_00324960	SVCTBA_F_00326296	SVCTBA_F_00326768	400 - 50
SVCTBA_F_00324154	SVCTBA_F_00324968	SVCTBA_F_00326304	SVCTBA_F_00326776	400 - 100
SVCTBA_F_00324162	SVCTBA_F_00324976	SVCTBA_F_00326312	SVCTBA_F_00326784	400 - 150
SVCTBA_F_00324170	SVCTBA_F_00324984	SVCTBA_F_00326320	SVCTBA_F_00326792	400 - 200
SVCTBA_F_00324178	SVCTBA_F_00324992	SVCTBA_F_00326328	SVCTBA_F_00326800	400 - 225
SVCTBA_F_00324186	SVCTBA_F_00325000	SVCTBA_F_00326336	SVCTBA_F_00326808	400 - 300
SVCTBA_F_00324074	SVCTBA_F_00324888	SVCTBA_F_00326214	SVCTBA_F_00326696	450 - 50
SVCTBA_F_00324082	SVCTBA_F_00324896	SVCTBA_F_00326222	SVCTBA_F_00326704	450 - 250
SVCTBA_F_00324098	SVCTBA_F_00324912	SVCTBA_F_00326238	SVCTBA_F_00326720	450 - 100
SVCTBA_F_00324106	SVCTBA_F_00324920	SVCTBA_F_00326246	SVCTBA_F_00326728	450 - 150
SVCTBA_F_00324114	SVCTBA_F_00324928	SVCTBA_F_00326254	SVCTBA_F_00326736	450 - 200
SVCTBA_F_00324122	SVCTBA_F_00324936	SVCTBA_F_00326264	SVCTBA_F_00326744	450 - 225
SVCTBA_F_00324130	SVCTBA_F_00324944	SVCTBA_F_00326280	SVCTBA_F_00326752	450 - 300
SVCTBA_F_00324138	SVCTBA_F_00324952	SVCTBA_F_00326288	SVCTBA_F_00326760	450 - 400
SVCTBA_F_00324010	SVCTBA_F_00324624	SVCTBA_F_00325674	SVCTBA_F_00326632	500 - 50
SVCTBA_F_00324018	SVCTBA_F_00324632	SVCTBA_F_00325682	SVCTBA_F_00326640	500 - 100
SVCTBA_F_00324026	SVCTBA_F_00324640	SVCTBA_F_00325690	SVCTBA_F_00326648	500 - 150
SVCTBA_F_00324034	SVCTBA_F_00324848	SVCTBA_F_00325698	SVCTBA_F_00326656	500 - 200
SVCTBA_F_00324042	SVCTBA_F_00324856	SVCTBA_F_00325706	SVCTBA_F_00326664	500 - 225
SVCTBA_F_00324050	SVCTBA_F_00324864	SVCTBA_F_00325722	SVCTBA_F_00326672	500 - 300
SVCTBA_F_00324058	SVCTBA_F_00324872	SVCTBA_F_00325714	SVCTBA_F_00326680	500 - 400
SVCTBA_F_00324066	SVCTBA_F_00324880	SVCTBA_F_00325730	SVCTBA_F_00326688	500 - 450
SVCTBA_F_00323938	SVCTBA_F_00324510	SVCTBA_F_00325602	SVCTBA_F_00326560	600 - 50
SVCTBA_F_00323946	SVCTBA_F_00324518	SVCTBA_F_00325610	SVCTBA_F_00326568	600 - 100
SVCTBA_F_00323954	SVCTBA_F_00324526	SVCTBA_F_00325618	SVCTBA_F_00326576	600 - 150
SVCTBA_F_00323962	SVCTBA_F_00324534	SVCTBA_F_00325626	SVCTBA_F_00326584	600 - 200
SVCTBA_F_00323970	SVCTBA_F_00324542	SVCTBA_F_00325634	SVCTBA_F_00326592	600 - 225
SVCTBA_F_00324090	SVCTBA_F_00324592	SVCTBA_F_00325642	SVCTBA_F_00326600	600 - 300
SVCTBA_F_00323986	SVCTBA_F_00324600	SVCTBA_F_00325650	SVCTBA_F_00326608	600 - 400
SVCTBA_F_00323994	SVCTBA_F_00324608	SVCTBA_F_00325658	SVCTBA_F_00326616	600 - 450
SVCTBA_F_00324002	SVCTBA_F_00324616	SVCTBA_F_00325666	SVCTBA_F_00326624	600 - 500
SVCTBA_F_00323834	SVCTBA_F_00324430	SVCTBA_F_00325522	SVCTBA_F_00326480	700 - 50
SVCTBA_F_00323842	SVCTBA_F_00324438	SVCTBA_F_00325530	SVCTBA_F_00326488	700 - 100



Note: Available thicknesses 1.0mm, 1.20mm, 1.50mm and 2.00mm

	Item Code			Cable Tray
Medium Duty (MCT) 1.2mm Thickness	Medium Duty (MCT) 1.2mm Thickness	Heavy Duty (HCT) 1.5mm Thickness	Very Heavy Duty (VCT) 2.0mm Thickness	Width mm
SVCTBA_F_00323850	SVCTBA_F_00324446	SVCTBA_F_00325538	SVCTBA_F_00326496	700 - 150
SVCTBA_F_00323860	SVCTBA_F_00324454	SVCTBA_F_00325546	SVCTBA_F_00326504	700 - 200
SVCTBA_F_00323868	SVCTBA_F_00324462	SVCTBA_F_00325554	SVCTBA_F_00326512	700 - 225
SVCTBA_F_00323876	SVCTBA_F_00324470	SVCTBA_F_00325562	SVCTBA_F_00326520	700 - 300
SVCTBA_F_00323892	SVCTBA_F_00324478	SVCTBA_F_00325570	SVCTBA_F_00326528	700 - 400
SVCTBA_F_00323910	SVCTBA_F_00324486	SVCTBA_F_00325578	SVCTBA_F_00326536	700 - 450
SVCTBA_F_00323920	SVCTBA_F_00324494	SVCTBA_F_00325586	SVCTBA_F_00326544	700 - 500
SVCTBA_F_00323928	SVCTBA_F_00324502	SVCTBA_F_00325594	SVCTBA_F_00326552	700 - 600
SVCTBA_F_00324320	SVCTBA_F_00325128	SVCTBA_F_00326464	SVCTBA_F_00326936	750 - 250
SVCTBA_F_00324328	SVCTBA_F_00325136	SVCTBA_F_00326472	SVCTBA_F_00326944	900 - 300



(Side Height 50 mm)

	Item Code			Cable Tray
Medium Duty (MCT) 1.2mm Thickness	Medium Duty (MCT) 1.2mm Thickness	Heavy Duty (HCT) 1.5mm Thickness	Very Heavy Duty (VCT) 2.0mm Thickness	Width mm
SVCTBA_F_00068775	SVCTBA_F_00050503	SVCTBA_F_00051673	SVCTBA_F_00090929	100 - 50
SVCTBA_F_00190139	SVCTBA_F_00079923	SVCTBA_F_00091437	SVCTBA_F_00090937	150 - 50
SVCTBA_F_00027236	SVCTBA_F_00027228	SVCTBA_F_00027220	SVCTBA_F_00027212	150 - 100
SVCTBA_F_00327608	SVCTBA_F_00067517	SVCTBA_F_00106167	SVCTBA_F_00244253	200 - 50
SVCTBA_F_00074569	SVCTBA_F_00113521	SVCTBA_F_00043800	SVCTBA_F_00236385	200 - 100
SVCTBA_F_00092437	SVCTBA_F_00119857	SVCTBA_F_00328218	SVCTBA_F_00328502	200 - 150
SVCTBA_F_00100929	SVCTBA_F_00089635	SVCTBA_F_00091429	SVCTBA_F_00102167	225 - 50
SVCTBA_F_00027180	SVCTBA_F_00027172	SVCTBA_F_00027164	SVCTBA_F_00027148	225 - 100
SVCTBA_F_00027132	SVCTBA_F_00027124	SVCTBA_F_00027116	SVCTBA_F_00027100	225 - 150
SVCTBA_F_00327590	SVCTBA_F_00327928	SVCTBA_F_00051007	SVCTBA_F_00328494	225 - 200
SVCTBA_F_00286080	SVCTBA_F_00253071	SVCTBA_F_00211809	SVCTBA_F_00328486	300 - 50
SVCTBA_F_00027084	SVCTBA_F_00027076	SVCTBA_F_00027068	SVCTBA_F_00027052	300 - 100
SVCTBA_F_00027036	SVCTBA_F_00027028	SVCTBA_F_00027012	SVCTBA_F_00026996	300 - 150
SVCTBA_F_00026980	SVCTBA_F_00026972	SVCTBA_F_00026964	SVCTBA_F_00026948	300 - 200
SVCTBA_F_00026932	SVCTBA_F_00026940	SVCTBA_F_00026908	SVCTBA_F_00026892	300 - 225
SVCTBA_F_00139579	SVCTBA_F_00062923	SVCTBA_F_00050983	SVCTBA_F_00088549	400 - 300
SVCTBA_F_00327666	SVCTBA_F_00327888	SVCTBA_F_00211801	SVCTBA_F_00328470	400 - 50
SVCTBA_F_00327690	SVCTBA_F_00135827	SVCTBA_F_00060075	SVCTBA_F_00120477	400 - 100
SVCTBA_F_00327698	SVCTBA_F_00244979	SVCTBA_F_00139771	SVCTBA_F_00200653	400 - 150
SVCTBA_F_00139323	SVCTBA_F_00244987	SVCTBA_F_00060067	SVCTBA_F_00225311	400 - 200
SVCTBA_F_00327706	SVCTBA_F_00327912	SVCTBA_F_00139763	SVCTBA_F_00328478	400 - 225
SVCTBA_F_00327536	SVCTBA_F_00089643	SVCTBA_F_00211793	SVCTBA_F_00174543	450 - 50
SVCTBA_F_00327554	SVCTBA_F_00327870	SVCTBA_F_00220861	SVCTBA_F_00328518	450 - 250
SVCTBA_F_00026876	SVCTBA_F_00026868	SVCTBA_F_00026860	SVCTBA_F_00026844	450 - 100
SVCTBA_F_00026828	SVCTBA_F_00026820	SVCTBA_F_00026812	SVCTBA_F_00026796	450 - 150
SVCTBA_F_00172247	SVCTBA_F_00065191	SVCTBA_F_00078643	SVCTBA_F_00159781	450 - 200
SVCTBA_F_00026780	SVCTBA_F_00026772	SVCTBA_F_00026764	SVCTBA_F_00026748	450 - 225
SVCTBA_F_00026732	SVCTBA_F_00026724	SVCTBA_F_00026716	SVCTBA_F_00026708	450 - 300
SVCTBA_F_00327572	SVCTBA_F_00108411	SVCTBA_F_00139755	SVCTBA_F_00328462	450 - 400
SVCTBA_F_00327468	SVCTBA_F_00327838	SVCTBA_F_00211753	SVCTBA_F_00328414	500 - 50
SVCTBA_F_00327476	SVCTBA_F_00205975	SVCTBA_F_00211761	SVCTBA_F_00328422	500 - 100
SVCTBA_F_00327484	SVCTBA_F_00327846	SVCTBA_F_00328146	SVCTBA_F_00328430	500 - 150
SVCTBA_F_00327682	SVCTBA_F_00274685	SVCTBA_F_00211769	SVCTBA_F_00142751	500 - 200
SVCTBA_F_00026588	SVCTBA_F_00327854	SVCTBA_F_00328166	SVCTBA_F_00328438	500 - 225
SVCTBA_F_00327492	SVCTBA_F_00026580	SVCTBA_F_00026540	SVCTBA_F_00026572	500 - 300
SVCTBA_F_00327510	SVCTBA_F_00327862	SVCTBA_F_00211777	SVCTBA_F_00328446	500 - 400
SVCTBA_F_00327510	SVCTBA_F_00208491	SVCTBA_F_00211785	SVCTBA_F_00142743	500 - 450



Note: Available thicknesses 1.0mm, 1.20mm, 1.50mm and 2.00mm

	Item Code			Cable Tray
Medium Duty (MCT) 1.2mm Thickness	Medium Duty (MCT) 1.2mm Thickness	Heavy Duty (HCT) 1.5mm Thickness	Very Heavy Duty (VCT) 2.0mm Thickness	Width mm
SVCTBA_F_00327396	SVCTBA_F_00327802	SVCTBA_F_00211745	SVCTBA_F_00230913	600 - 50
SVCTBA_F_00094681	SVCTBA_F_00085173	SVCTBA_F_00328062	SVCTBA_F_00328342	600 - 100
SVCTBA_F_00327412	SVCTBA_F_00085165	SVCTBA_F_00328072	SVCTBA_F_00328350	600 - 150
SVCTBA_F_00327424	SVCTBA_F_00234481	SVCTBA_F_00328080	SVCTBA_F_00328358	600 - 200
SVCTBA_F_00327432	SVCTBA_F_00041950	SVCTBA_F_00328096	SVCTBA_F_00328366	600 - 225
SVCTBA_F_00327440	SVCTBA_F_00074501	SVCTBA_F_00328104	SVCTBA_F_00328374	600 - 300
SVCTBA_F_00327448	SVCTBA_F_00051409	SVCTBA_F_00328116	SVCTBA_F_00328390	600 - 400
SVCTBA_F_00327674	SVCTBA_F_00041958	SVCTBA_F_00328124	SVCTBA_F_00328398	600 - 450
SVCTBA_F_00327460	SVCTBA_F_00327830	SVCTBA_F_00328132	SVCTBA_F_00328406	600 - 500
SVCTBA_F_00327312	SVCTBA_F_00327714	SVCTBA_F_00211689	SVCTBA_F_00328270	700 - 50
SVCTBA_F_00327320	SVCTBA_F_00327722	SVCTBA_F_00088753	SVCTBA_F_00328278	700 - 100
SVCTBA_F_00327328	SVCTBA_F_00327730	SVCTBA_F_00211697	SVCTBA_F_00328286	700 - 150
SVCTBA_F_00327336	SVCTBA_F_00327738	SVCTBA_F_00211705	SVCTBA_F_00328294	700 - 200
SVCTBA_F_00327344	SVCTBA_F_00327746	SVCTBA_F_00211713	SVCTBA_F_00328302	700 - 225
SVCTBA_F_00327352	SVCTBA_F_00327754	SVCTBA_F_00211721	SVCTBA_F_00200629	700 - 300
SVCTBA_F_00327360	SVCTBA_F_00327762	SVCTBA_F_00211729	SVCTBA_F_00328310	700 - 400
SVCTBA_F_00327368	SVCTBA_F_00327770	SVCTBA_F_00088761	SVCTBA_F_00328318	700 - 450
SVCTBA_F_00327376	SVCTBA_F_00327778	SVCTBA_F_00211737	SVCTBA_F_00328326	700 - 500
SVCTBA_F_00327384	SVCTBA_F_00327794	SVCTBA_F_00149035	SVCTBA_F_00328334	700 - 600
SVCTBA_F_00327632	SVCTBA_F_00327936	SVCTBA_F_00328226	SVCTBA_F_00328510	750 - 250
SVCTBA_F_00327652	SVCTBA_F_00327952	SVCTBA_F_00328242	SVCTBA_F_00026056	900 - 300



Note: Available thicknesses 1.0mm, 1.20mm, 1.50mm and 2.00mm

ADJUSTABLE RISER / 640

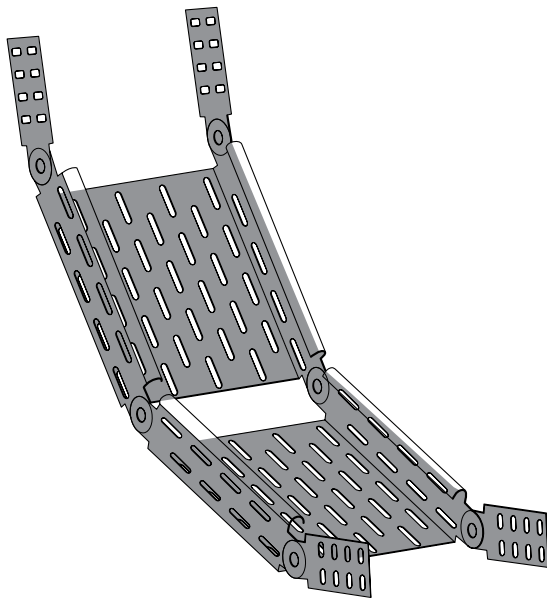

(Side Height 50 mm)

2mm Thickness	
Item Code	Width
SVCTBA_F_00179683	100
SVCTBA_F_00189721	150
SVCTBA_F_00179691	200
SVCTBA_F_00189713	225
SVCTBA_F_00047164	300
SVCTBA_F_00047292	450
SVCTBA_F_00047228	600
SVCTBA_F_00047212	750
SVCTBA_F_00047148	900

(Side Height 100 mm)

2mm Thickness	
Item Code	Width
SVCTBA_F_00326970	100
SVCTBA_F_00258663	150
SVCTBA_F_00326978	200
SVCTBA_F_00326992	225
SVCTBA_F_00327000	300
SVCTBA_F_00327008	450
SVCTBA_F_00327020	600
SVCTBA_F_00327028	750
SVCTBA_F_00327036	900



Width (mm)	Order Example						
	Item	(h)	(w)	(t)	Type	(l)	(r)
50	640	050	0050	2	RFI	3000	45
100	640	050	0100	2	RFI	3000	45

Order Example:

640 - Side height (h) - Width(w) - Thickness - Side type

For more ordering details, please check pages 64-65

CUSTOM RISERS

For inquiries, use same code as adjustable risers and add the angle desired at the end, ex:

For custom riser 45° angle
- 640 050 0300 4 STR 3000/45

For custom riser 60° angle
- 660 050 0300 4 STR 3000/60

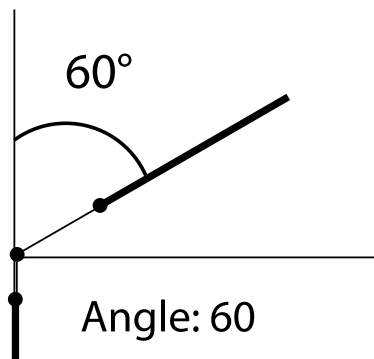
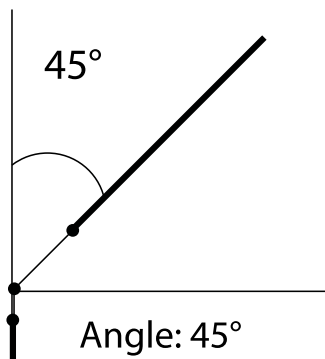

Custom risers are suitable for 45° and 60° angles



CABLE TRAY ACCESSORIES

Straight connector / 1000

1000



Order Example:
1000 - Side height (h) - Thickness (t), For more ordering details, please check pages 64-65

Order Example		
Item Code	(h)	(t)
1000-50	050	2
1000-75	075	2
1000-100	100	2

Angle Connector / 1010

1010



Order Example:
1010 - Side height (h) - Thickness (t), For more ordering details, please check pages 64-65

Order Example		
Item Code	(h)	(t)
1010-50	050	2
1010-75	075	2
1010-100	100	2

1030

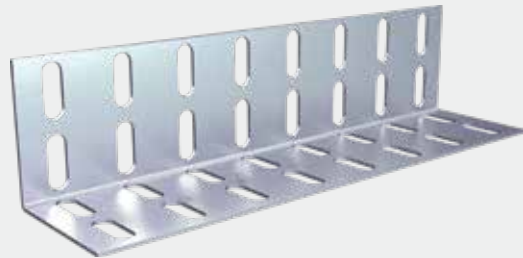

Order Example:
1030 - Side height (h) - Thickness (t), For more ordering details, please check pages 64-65

Order Example		
Item Code	(h)	(t)
1030-50	050	2
1030-75	075	2
1030-100	100	2

Wrap Over Coupler / 1050 - 1030

1050



Order Example:
1050 - Side height (h) - Thickness (t), For more ordering details, please check pages 64-65

Order Example		
Item Code	(h)	(t)
1050-50	050	2
1050-75	075	2
1050-100	100	2

Expansion Connector / 1020

1020



Order Example

Item Code	(h)	(t)
1020-50	050	2
1020-75	075	2
1020-100	100	2

Order Example:
1020 - Side height (h)
Thickness (t)
For more ordering details,
please check pages 74-75

Expansion Joint Plate - Fish Plate / 1085

1085



Order Example

Item Code	(h)	(t)
1085-50	050	2
1085-75	075	2
1085-100	100	2

Order Example:
1085 - Side height (h)
Thickness (t)
For more ordering details,
please check pages 74-75

Horizontal Adjustable Connector / 1060

1060

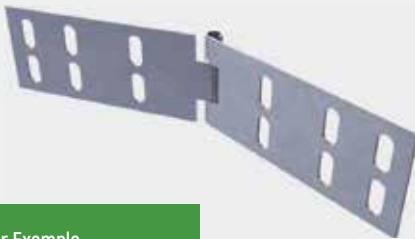

Order Example

Item Code	(h)	(t)
1060-50	050	2
1060-75	075	2
1060-100	100	2

Order Example:
1060 - Side height (h)
Thickness (t)
For more ordering details,
please check pages 74-75

Vertical Adjustable Connector / 1050

1050



Order Example

Item Code	(h)	(t)
1050-50	050	2
1050-75	075	2
1050-100	100	2

Order Example:
1050 - Side height (h)
Thickness (t)
For more ordering details,
please check pages 74-75

End Plate / 1090

1090



Order Example

Item Code	(h)	(t)
1090-50	050	2
1090-75	075	2
1090-100	100	2

Order Example:
1090 - Side height (h)
Thickness (t)
For more ordering details,
please check pages 74-75

Drop-out Plate / 2000

2000

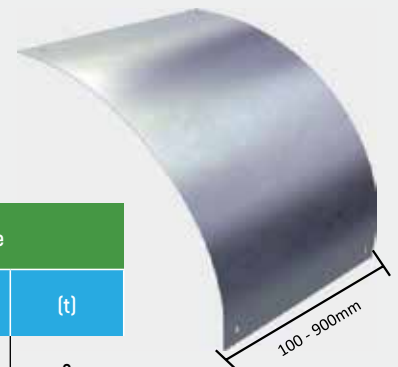

Order Example

Item Code	(h)	(t)
1090-50	050	2
1090-75	075	2
1090-100	100	2

Order Example:
2000 - Side height (h)
Thickness (t)
For more ordering details,
please check pages 74-75

Crimping Type Copper / 2100

Tubular Cable Terminal Ends

2100

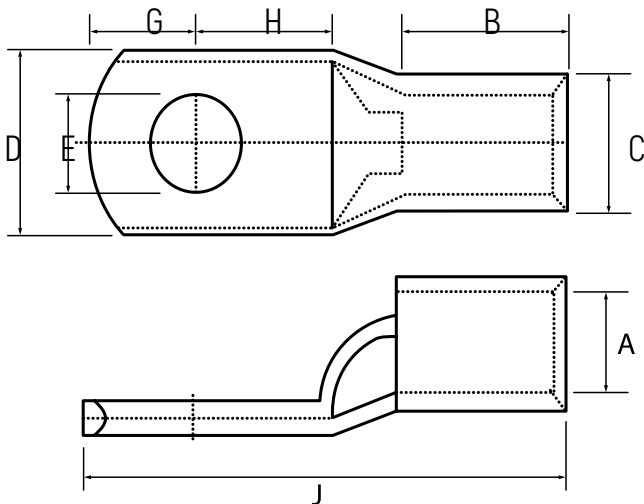

Cable mm	Stud Hole	Dimensions (mm)						
		A	C	D	G	H	B	J
1.5	6.5	1.8	3.7	10	4	6	6	18
	8.4	2.4	4.2	12	6	9	8	26
2.5	6.5	2.4	4	10	5	6	8	21
	8.4	3.1	5.0	12	6	9	8	26
4	6.5	3.1	4.8	10	5	6	8	21
	8.4	3.8	5.5	12	6	9	10	24
6	6.5	3.8	5.5	12	5	6	10	24
	8.4	4.5	6.2	11	6	7	10	26
10	6.5	4.5	6.2	12	6	9	10	28
	8.4	5.4	7.1	12	7	7	12	30
16	6.5	5.4	7.1	12	7	7	12	30
	8.4	6	7.7	12	7	7	12	32
20	6.5	6.8	8.8	13	7	7	12	30
	8.4	6.8	8.8	13	7	7	12	30

Tinned Copper Flexible Braids / 2200

Crimped with Connectors/ Terminals

2200

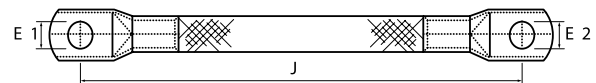

HFT- crimped with lugs

Size, mm	Dimensions (mm)			Current rating AMP
	J	E1	E2	
4	50	6	6	50
	100	6	6	50
	150	6	6	50
	200	6	6	50
10	50	6	6	90
	100	6	6	90
	150	6	6	90
	200	6	6	90
16	100	8.5	8.5	125
	150	8.5	8.5	125
	200	8.5	8.5	125
	250	8.5	8.5	125
	300	8.5	8.5	125
25	100	10	10	160
	150	10	10	160
	200	10	10	160
	250	10	10	160
	300	10	10	160

Cable tray cover

Functions

Cable tray covers shall be considered for any of the following purposes:

- Protection from falling objects or debris, as may occur beneath personnel walkways.
- Shielding from ultra-violet rays of the sun and guarding against other weathering elements.
- Minimizing accumulation of foreign contaminants such as ash or other industrial deposits.
- Protection of cables and personnel where a riser tray penetrates a floor or grating.

Solid Cover / 3000

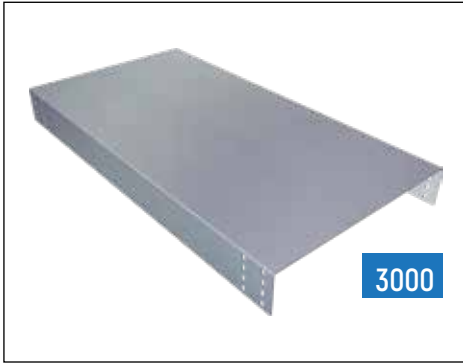

Covers Side Height Types:

- Solid without flange - (SOF)
- Solid with flange - (SWF)
- Ventilated without flange - (VOF)
- Ventilated with flange - (VWF)

Ventilated Cover / 3100



- Cable Ladder covers are supplied with or without a 15 mm down turned flange.
- Straight section covers are furnished 3000 mm long. All fitting covers are furnished in solid design only.

Cable tray cover with locking clamp / 3200



Covers Side Height Types :

- Solid without flange- (VOF)
- Solid with flange- (VWF)

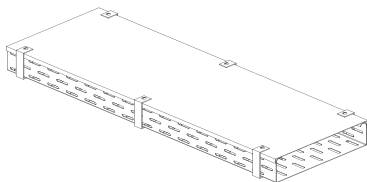
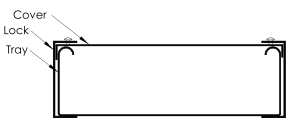

Locking Clamp:

Thickness: 2mm

3300



Spring Down Clamp:

Thickness: 2mm

3301

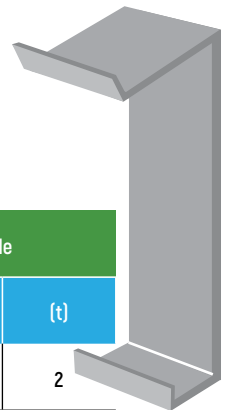

Order Example

Item Code	(h)	(t)
3300-50	050	2
3300-75	075	2
3300-100	100	2

Order Example:

3300 - Side height (h) - Thickness (t)
For more ordering details, please check pages 64-65

Order Example

Item Code	(h)	(t)
3301-50	050	2
3301-75	075	2
3301-100	100	2

Order Example:

3301 - Side height (h) - Thickness (t)
For more ordering details, please check pages 64-65

Item	Item Code
Solid Cover	SVCTCS - F - 00044554
Ventilated Cover	SVCTIS - F - 001316105
Locking Clamp	STCB - F - 00178149

FRAMING SYSTEMS

ASTM F436

Washers (SRW) | DIN 125 | ASTM F436

Zinc Plated	Stainless Steel	D	d	S
		(mm)	(mm)	(mm)
M6	M6	12	6.4	1.6
M8	M8	16	8.4	1.6
M10	M10	21	10.5	2
M12	M12	24	13	2.5
M16	M16	30	17	3
M18	M18	34	19	3.2
M20	M20	39	20.5	3.6



Order Example: SRW - M 12 -DIN 115

Round Washers DIN 440, DIN 9021

Washers (SRW) | DIN 440 | DIN 9021

DIN	Zinc Plated	Stainless Steel	D	d	S
			(mm)	(mm)	(mm)
440	M6		22	6.6	2
9021	M8	M8	24	8.4	2
9021	M10	M10	30	10.5	2.5
440	M12		45	13.5	4
9021	M12	M12	37	13	3
9021	M16	M16	50	17	3



Order Example: SRW - M 12 DIN 9021

Square Washers SSW

Square Washers (SSW)

H.D. Galvanized Bolt	Stainless Steel Bolt	a x b x d
		(mm)
M8	M10	40 x 40 x (4-5-6)
M10	M12	40 x 40 x (4-5-6)
M12	M16	40 x 40 x (4-5-6)

SSW 40/40 for all channels
41/21 Series

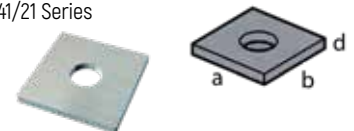

SSW 41/41 for all channels
41/41 Series

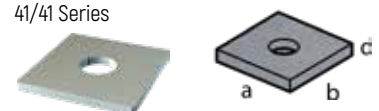

Order Example: SSW 41/41 M 12 - d

Fully Threaded Rods Grade 4.6 DIN 975 ASTM A 36, A193

Threaded Rod (STR) - DIN 975 - ASTM A36

Zinc Plated Thread	Length	Load cap.
	(mm)	(kN)
M6	2000/3000	2.2
M8	2000/3000	4.0
M10	2000/3000	6.4
M12	2000/3000	12.9
M16	2000/3000	17.3
M18	2000	22.0
M20	2000	27.0



Round Head Machine Screws

Round Head (SRH) | DIN 7985

Zinc Plated Thread	Length	d
	(mm)	(mm)
M6	30-40	6.0
M8	30-40	8.0
M10	20-60	10.0



SRH - M10 DIN 7985

Coupler Sleeves Rounded

Coupler Sleeves (SCS)

Electro-plated Thread	Stainless Steel Thread	D	L	Load Capacity
		(mm)	(mm)	(kN)
M6	M6	10/10	15	2.2
M8	M8	12/14	20	4.0
M10	M10	13/16	25	6.4
M12	M12	16/20	30	9.3
M16	M16	21/25	40	17.3
M20	M20	26/32	50	27.0



SCS - M16

Roofing Bolts

Roofing Bolts (SRB)

- Materials : low carbon steel , carbon steel
- Steel S235 , grade 4.6 , 4.8 and 8.8
- Surfaces : plain , black and zinc plated
- Length = X (mm) – Y (mm)



Thread Size	M4 x - y	M5 x - y	M6 x - y	M8 x - y
	(mm)	(mm)	(mm)	(mm)
Length	10 - 50	10 - 80	12 - 120	16 - 150

Order Example: SRB - M6

Carriage Bolts with Nut Below Head DIN 603

Carriage Bolts (STC)

Zinc Plated	H.D. Galvanized Grade 4.6	Head	Head	Square Width	Square Depth
(E)	(E)	(A) mm	(H) mm	(O) mm	(P) mm
M5	M5	12.0	3.0	5.0	3.2
M6	M6	15.1	3.70	6.40	4.0
M8	M8	18.3	4.50	8.23	4.75
M10	M10	21.44	5.30	9.86	5.56
M16	M16	34.14	8.74	16.3	8.74



Order Example: STC - M6

Hexagon Nuts DIN 934, DIN EN 24032, ASTM A 563

Hexagon nut (SHN) | DIN 934 or ISO 4032 (= DIN EN 24032) | ASTM A563

Zinc Plated Thread	Stainless Steel Thread	S/m DIN	S/m ISO	e
		(mm)	(mm)	(mm)
M6	M6	10/5	10/6	11.5
M8	M8	13/6.5	13/7.5	15.0
M10	M10	17/8	16/9.5	19.6
M12	M12	19/10	18/12	21.9
M16	M16	24/13	24/15.5	27.7
M18	M18	26/16	26/16	22.0
M20	M20	30/18	29/20.5	27.0



Order Example: SHN - M12

Hexagonal Rod Coupler Grade 8.8 ASTM a 563

Hexagonal Rod Coupler with view hole (SHR)

Electroplated Thread	Stainless Steel Thread	D	L	Load capacity
		(mm)	(mm)	(kN)
M10	M10	13	40	6.4
M12	M12	17	40	9.3
M16	M16	22	50	17.3
M 18	M 18	23	60	22.0
M 20	M 20	25	70	27.0



Order Example: HRC - GV - M 12

DIN 933, DIN 24017, ASTM A307, A449

Hex Head Bolt (SHB) | DIN 933 or EN 24017 ASTM A307, A449 (without nut)

Zinc Plated Dimension	Stainless Steel Dimension	S DIN	S EN
		(mm)	(mm)
M 6 x 12		10	10
M 6 x 25			
M 8 x 25	M 8 x 25	13	13
M 8 x 40			
M 10 x 20		17	16
M 10 x 30	M 10 x 30		
M 10 x 45	M 10 x 45		
M 10 x 60			
M 10 x 70			
M 12 x 22		19	18
M 12 x 25	M 12 x 25		
M 12 x 30	M 12 x 30		
M 12 x 40	M 12 x 40		
M 12 x 50			
M 12 x 60	M 12 x 60		
M 12 x 80	M 12 x 80		
M 12 x 90			
M 16 x 40	M 16 x 40	24	24
M 16 x 60	M 16 x 60		
M 16 x 90	M 16 x 90		
M 18 x 40	M 18 x 40	27	26
M 18 x 50	M 18 x 50		
M 18 x 60	M 18 x 60		
M 18 x 80	M 18 x 80		
M 20 x 40	M 20 x 40	32	32
M 20 x 50	M 20 x 50		
M 20 x 60	M 20 x 60		
M 20 x 80	M 20 x 80		



CABLE TRAY SUPPORT SYSTEM

GENERAL INFORMATION

CHANNEL

SFSP's metal framing channel is cold formed on modern rolling machines from low carbon steel manufactured according to BS 6946:1988. A continuous slot provides the ability to make attachments at any point.

LENGTHS

Standard length: 3000mm with ± 3.2 mm length tolerance.
Custom lengths are available upon request.

FINISHES

Standard Finishes: Pre-Galvanized finish (ASTM A653M coating G90 and G60). Hot Dip Galvanized after fabrication (ASTM A123 or BSEN ISO1461:2009). Other custom coatings are available upon request.

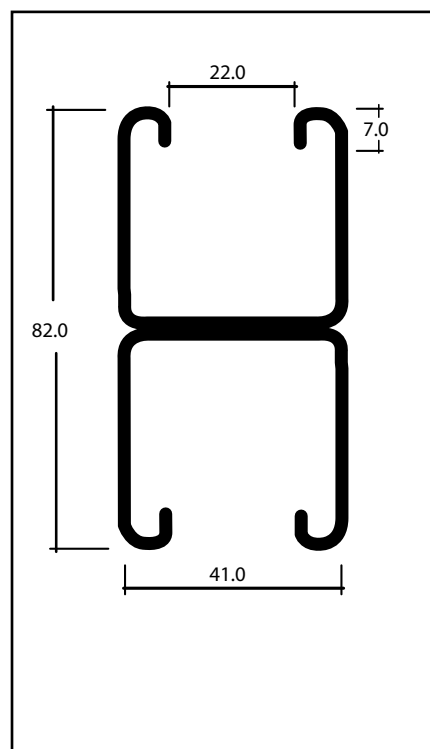
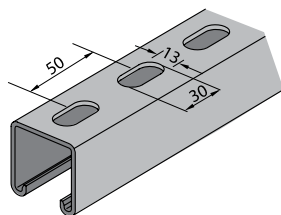
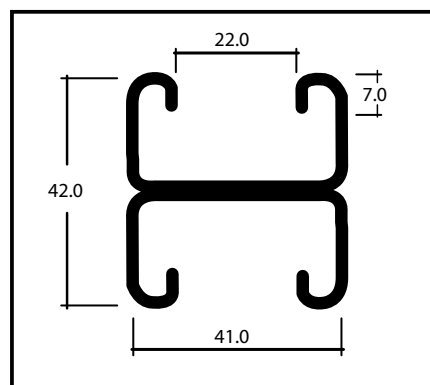
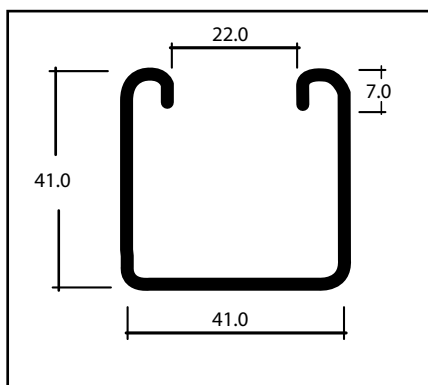
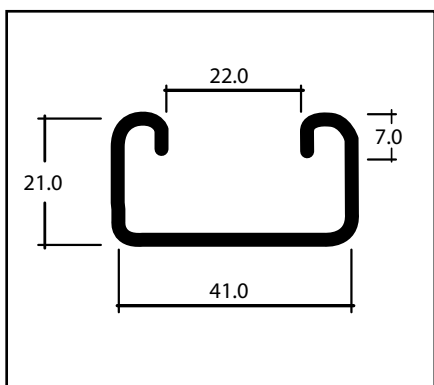

Metal Framing Channels

SELECTION CHART

Part No	Channel Dimensions		Thickness
	Height "H"	Width "W"	
CCH - 220/221	21.0 mm	41.0 mm	1.5 mm
CCH - 240/241	41.0 mm	41.0 mm	1.5 mm
CCH - 320/321	21.0 mm	41.0 mm	2.0 mm
CCH - 340/341	41.0 mm	41.0 mm	2.0 mm
CCH - 420/421	21.0 mm	41.0 mm	2.5 mm
CCH - 440/441	41.0 mm	41.0 mm	2.5 mm

For Toothed Channel add "T" after the Part no. ex.: CCH-220T

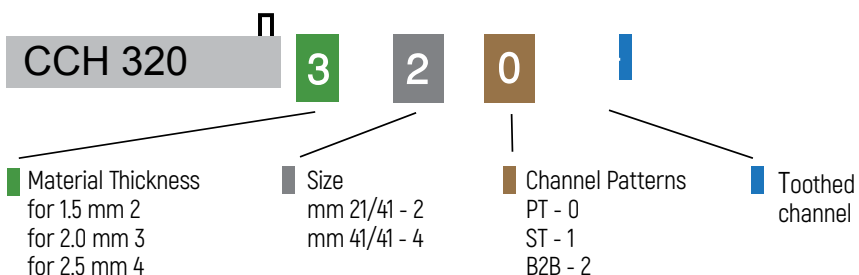

Channel Hole Patterns

PT PLAIN
TYPE



ST SLOTTED TYPE



B2B TYPE

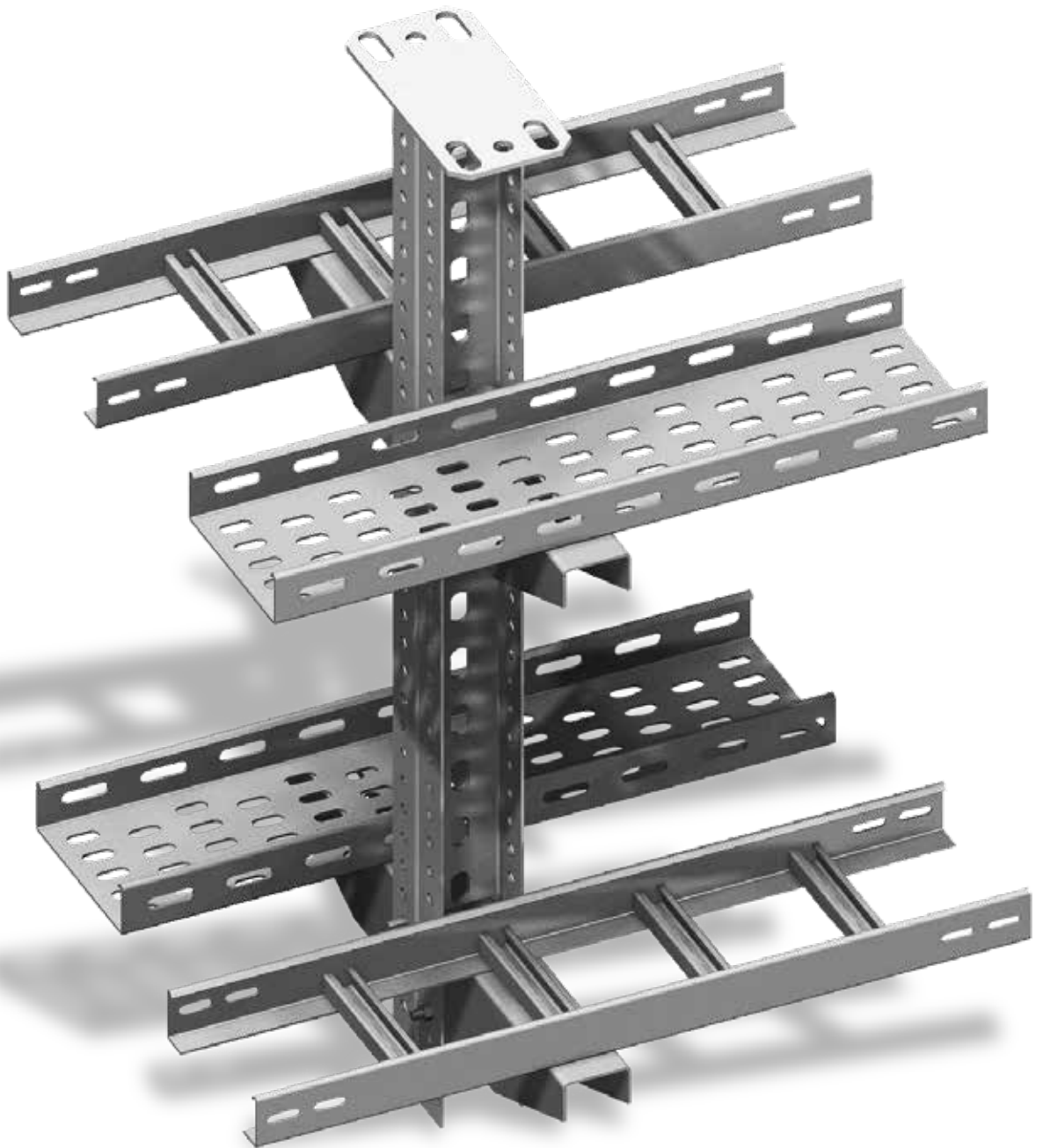

CANTILEVER ARM BRACKET

Cantilever Arm Brackets - SCA

CCH421 41x21x2.5

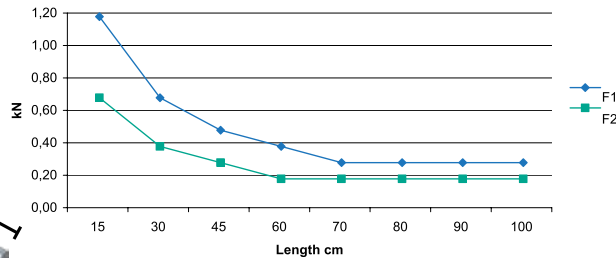
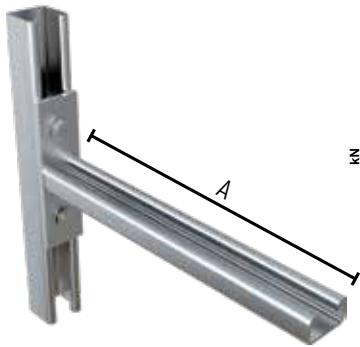

Length A (mm)	Allowable Load		
	F ₁ *	F ₂ *	F ₂ **
150	1.10	0.60	3.10
300	0.60	0.30	3.10
450	0.40	0.20	3.10
600	0.30	0.10	3.10
700	0.20	0.10	3.10
800	0.20	0.10	3.10
900	0.20	0.10	3.10
1000	0.20	0.10	3.10

Base plate : height (h) x width (b) x thickness (t)
100 50 8

- In the case of concrete support frame, use anchor M10
- In the case of concrete C-Channel frame, Hex bolt M8 .

** Connection force (pull-out force) : 3.10 [kN]

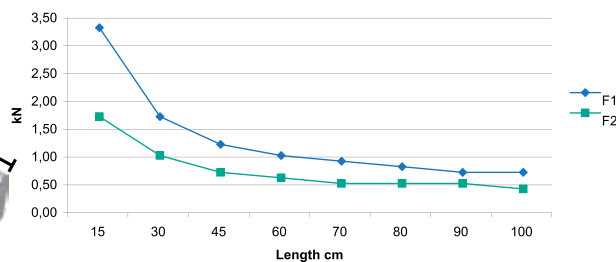
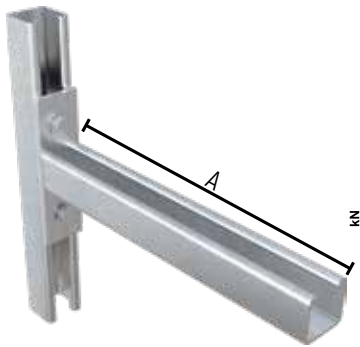

Length A (mm)	Allowable Load		
	F ₁ *	F ₂ *	F ₂ **
150	3.10	1.50	7.50
300	1.50	0.80	7.50
450	1.00	0.50	7.50
600	0.80	0.40	7.50
700	0.70	0.30	7.50
800	0.60	0.30	7.50
900	0.50	0.30	7.50
1000	0.50	0.20	7.50

Base plate : height (h) x width (b) x thickness (t)
140 50 10

- In the case of concrete support frame, use anchor M16 .
- In the case of concrete C-Channel frame, Hex bolt M8.

** Connection force (pull-out force) : 7.50 [kN]

* Given Loads are always in [kN] * Allowable characteristic live load *

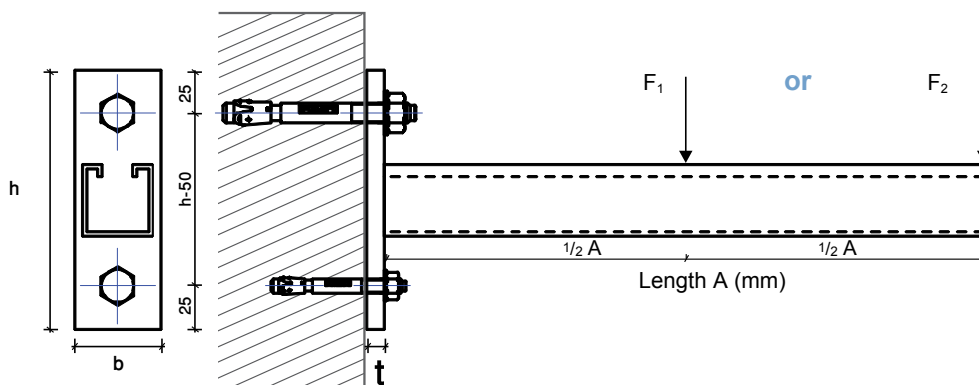

Cantilever Arm Brackets - SCA

CCH422 41x21x2.5 B2B

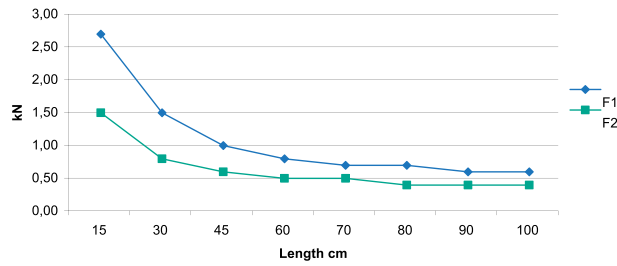
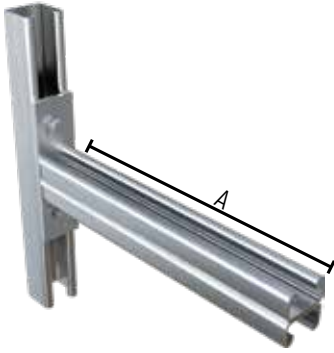

Length A (mm)	Allowable Load		
	F ₁ *	F ₂ *	F _z **
150	2.50	1.30	4.80
300	1.30	0.60	4.80
450	0.80	0.40	4.80
600	0.60	0.30	4.80
700	0.50	0.30	4.80
800	0.50	0.20	4.80
900	0.40	0.20	4.80
1000	0.40	0.20	4.80

Base plate : height (h) x width (b) x thickness (t)

140 50 10

- In the case of concrete support frame, use anchor M12.
- In the case of concrete C-Channel frame, Hexbolt M8.

** Connection force (pull-out force) : 4,8 [kN]

CCH442 41x41x2.5 B2B

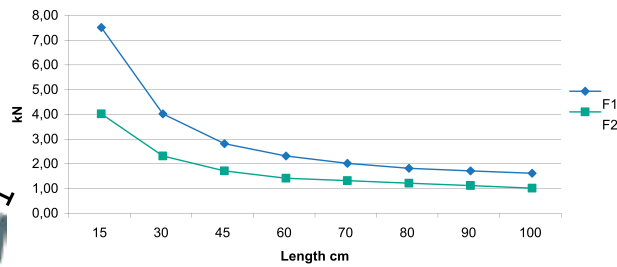
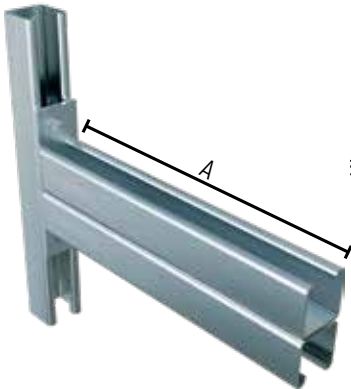

Length A (mm)	Allowable Load		
	F ₁ *	F ₂ *	F _z **
150	7.00	3.50	8.30
300	3.50	1.80	8.30
450	2.30	1.20	8.30
600	1.80	0.90	8.30
700	1.50	0.80	8.30
800	1.30	0.70	8.30
900	1.20	0.60	8.30
1000	1.10	0.50	8.30

Base plate : height (h) x width (b) x thickness (t)

180 60 12

- In the case of concrete support frame, use anchor M16.
- In the case of concrete C-Channel frame, Hex bolt M10 .

** Connection force (pull-out force) : 8,30 [kN]

* Given Loads are always in [kN] * Allowable characteristic live load *

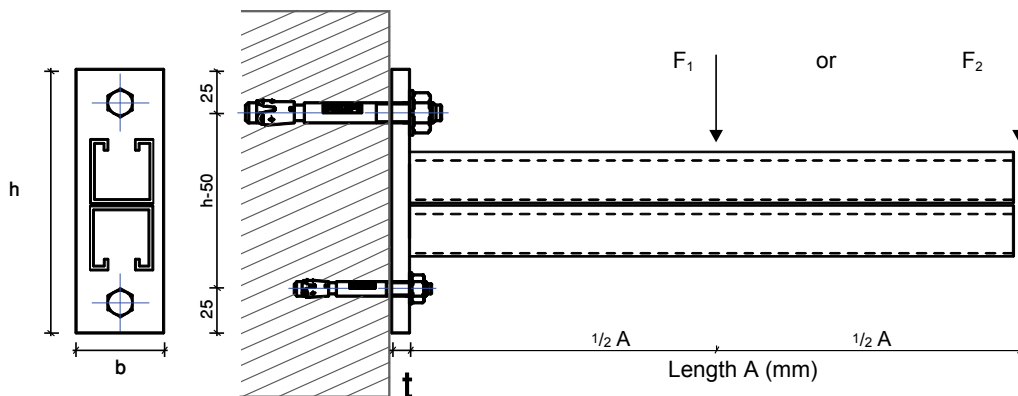

U - Support / 3000

3000

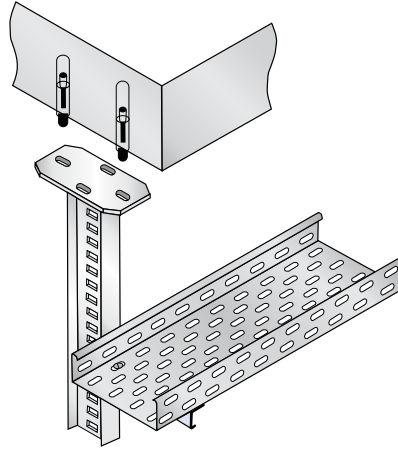
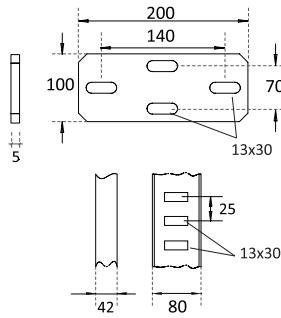
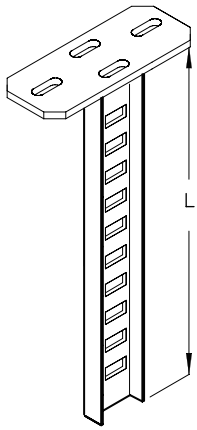

Order Example		
Item	(h)	(t)
3000	0200	5

Order Example:
3000 - Length (L) - Thickness (t)
For more ordering details, please check pages 64-65

U-Support with welded-on head plate 200 x 100 x 5mm

I - Support / 3050

3050

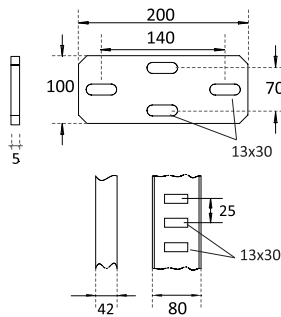
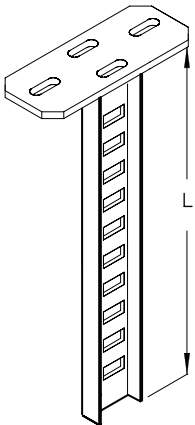

Order Example:
3050 - Length (L) - Thickness (t)
For more ordering details, please check pages 64-65

Head Plate / 3100

3100

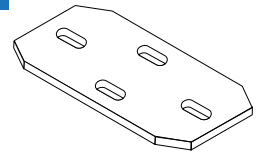

200 x 100 x 5mm

U-Support with welded-on head plate 200 x 100 x 5mm

Wall Bracket | 3200 - 3250

3200

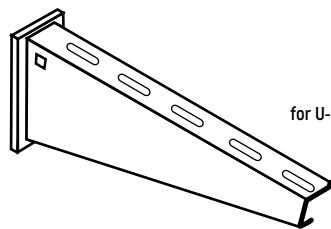

5 mm thickness

3250

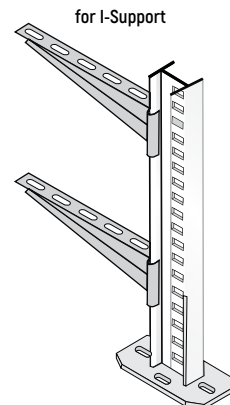

Order Example		
Item	(L)	(t)
3200	0210	5

Order Example:
3200 - Length (L) - Thickness (t)
For more ordering details, please check pages 64-65

Support connectors | 3300

3300

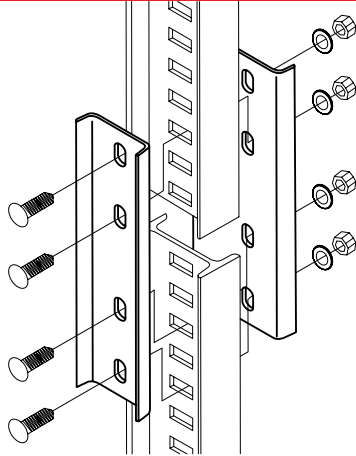

Clamping plates | 3350

3350

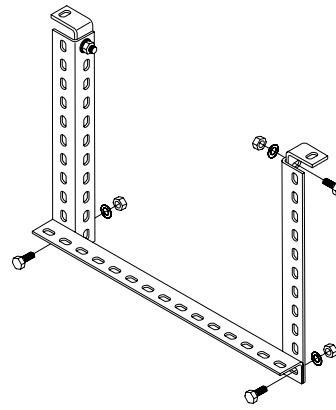

Order Example

Item	(L)	(t)
3300	0200	5

Order Example:
3300 - Length (L) - Thickness (t)
For more ordering details, please check pages 64-65

Order Example

Item	(L)	(t)
3350	0200	5

Order Example:
3350 - Length (L) - Thickness (t)
For more ordering details, please check pages 64-65

Support plates | 3400

3400

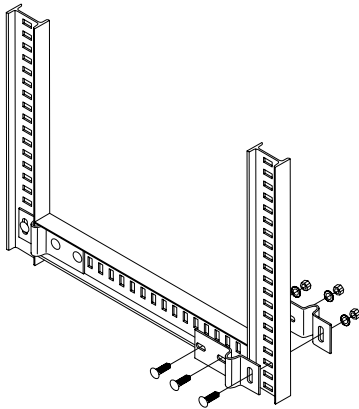

Support clamps | 3450

3450

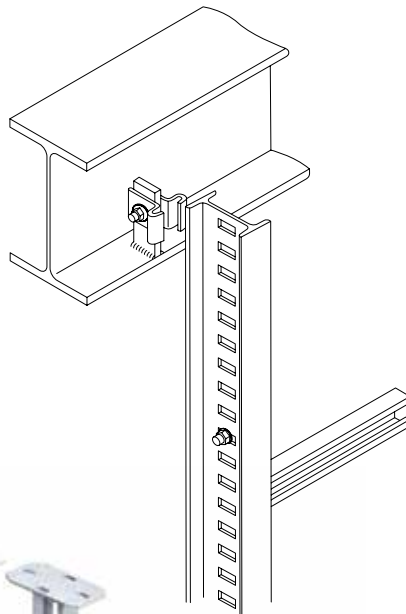

Clamping angles | 3550

3550

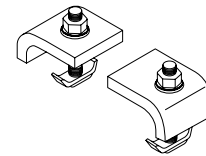

Head plate for welding

Head plate

Head plate: variable, transverse

Carrier lug

Head plate: variable, longitudinal

Support bracket

Support connector

Angles | 3600

3600



HOW TO ORDER

ORDERING CABLE TRAY

Side Height Varieties

Cable trays are available in the following side heights:

· 25 mm · 50 mm · 75 mm · 100 mm

* Other side heights can be manufactured upon request.

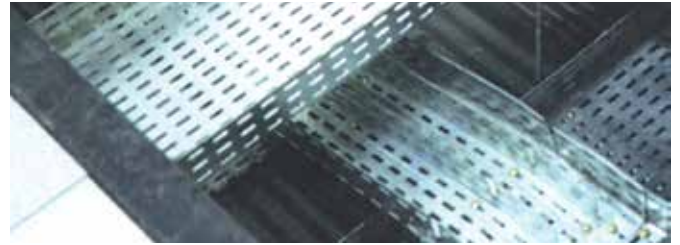

Cable trays and accessories are available in the following side height types:

Straight end

STR

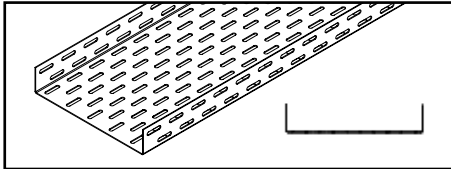

Return flange inside

RFI

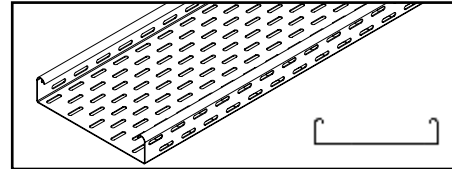

Return flange outside

RFO

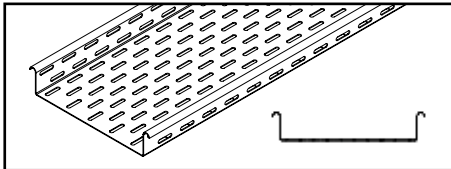

C - Type inside

CTI

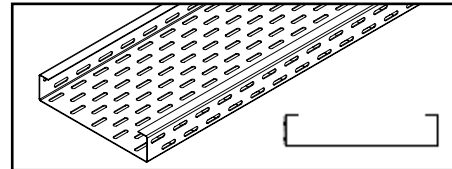

C - Type outside

CTO

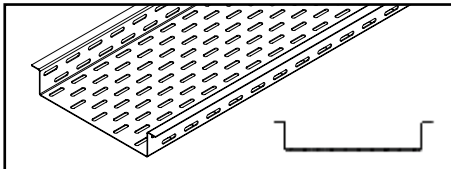

-Abbreviations

Materials & Finishes	Code
Stainless Steel	SS
Pre-Galvanized	PG
Aluminium	Al
Hot-dip Galvanized	HD
Electrolytic Galvanized	EG
Powder Coated	PC

Thickness	Code
Sheet of 1.0 mm	1
Sheet of 1.20 mm	2
Sheet of 1.50 mm	3
Sheet of 2.0 mm	4
Sheet of 5.0 mm	5

For more information on ordering and types, Uni-Metal technical staff are ready to assist you with all necessary details.
www.unimetal-ikk.com

ORDERING CABLE TRAY ACCESSORIES

Item & Order Number for Sections & Fittings

When ordering cable trays, the full order number shall include the material used, width of the tray, side height, type of side and the length of the tray.

Order Example								
120	050	0600	4/	RFI	3000	PG	PC	PD
↓	↓	↓	↓	↓	↓	↓	↓	↓
Item Number	Side Height	Width (mm)	Thickness (mm)	Side Type	Length (mm)	Pre. Galvanized (Materials)	Powder Coated (Finishes)	Perforation Dimension (20x7 & 32x7 mm)

Examples:

1- Order number for Hot-Dip Galvanized 2,400 mm length cable tray, 50 mm side height, 2mm sheet thickness and 500 mm width with outside return flange:

130 050 0500 4/RFO 2400 PG PC

2- Order number for Pre-Galvanized 3,000 mm length cable tray, 50 mm side height, 1.25 mm sheet thickness and 300 mm width with inside return flange:

110 050 0300 2/RFI 3000 PG PC

3- Order number for powder coated curved T-branch, 50 mm side height, 1.5 mm sheet thickness and 700 mm width with straight end:

320 050 0700 3/STR PG PC

N.B.: Order number for connectors will include the item number, side height and thickness of the sheet

General Information

Consideration shall be given to the following factors when undertaking the design of a cable tray run and a support system, although some of these (ex: wind loads) may not be relevant to every installation :

- Distributed loads e.g. cables, pipes.
- Point loads
- Thermal expansion & contraction
- Wind & external forces
- Spacing of supports
- Safety factor
- Deflection

Location of Couplers

In practice, it is often difficult to pre-determine where the couplers will be located within a straight run of a cable tray.

However, it is worth making some efforts to roughly plan their position during the early stages of installation. The worst positions of the couplers are either at mid-span or immediately over a point of support; at these locations they will suffer the greatest stress.

Both locations shall be particularly avoided at the end of an installation. From a practical viewpoint it is also more difficult to assemble or fix down a tray if the couplers are positioned immediately over the supports.

The best position of joints in a continuous installation is one quarter of the span distance on either side of each point of support.

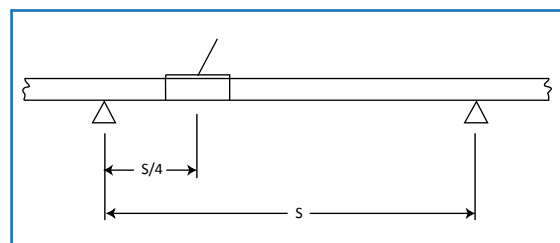

Contact Information

Sales Offices/Entities

KINGDOM OF SAUDI ARABIA

unitech.ksa@ikkgroup.com

Jeddah

Tel : +966 12 627 8222

Mak kah/Taif

Tel : +966 12 541 1206

Mad inah

Tel : +966 14 842 1095

Yanbu

Tel : +966 14 390 1499

Khamis Mushayt

Tel : +966 17 237 5929

Gizan

Tel : +966 17 321 6660

Riyadh

Tel : +966 11 292 8200

Qassim / Buraidah

Tel : +966 16 382 3946

Tabuk

Tel : +966 14 423 5203

Dammam

Tel : +966 13 859 0097

Hufuf

Tel : +966 13 530 1474

Jubail

Tel : +966 13 361 4390

UNITED ARAB EMIRATES

Dubai - Al Rashidiyah

unitech.dubai@ikkgroup.com

Tel : +971 4 2591 773

Abu Dhabi - Musaffah

unitech.auh@ikkgroup.com

Tel: +971 2 552 3393

BAHRAIN

Manama

unitech.bahrain@ikkgroup.com

Tel : +973 17 874 897

KUWAIT

Kuwait City

unitech.kuwait@ikkgroup.com

Tel : +965 2 2459 984

QATAR

Doha

info@unitech-qatar.com

Tel: +974 4451 3301

OMAN

Muscat

unitech.oman@ikkgroup.com

Tel : +968 24 591 006

LEBANON

Beirut

unitech.lebanon@ikkgroup.com

Tel : +961 1 858 277

EGYPT

Cairo 6th of October City

unitech.egypt@ikkgroup.com

Tel : +20 2 3820 6477

PAKISTAN

Lahore - Punjab

unitech.pakistan@ikkgroup.com

Tel: +92 42 32301578

SFSP Factories

SFSP - KSA

Specialized Factory for Steel Products

sfsp.jeddah@ikkgroup.com

3rd Industrial City / Jeddah

Tel: +966 12 637 4482

SFSP / UAE

SIGMA Factory for Steel Products

sfsp.uae@ikkgroup.com

DIC (Dubai Industrial City)

Tel : +971 4 818 1919

SFSP / EGYPT

Specialized Factory for Steel Products

sfsp.cairo@ikkgroup.com

6th of October City Giza

Tel : +20 2 3820 6477

SFSP / LEBANON

Specialized Factory for Steel Products / s.a.r.l

sfsp.lebanon@ikkgroup.com

Tanayel, Bekaa

Tel : +961 8 514 290

Engineering & Design

GERMANY

unitech.germany@ikkgroup.com

United Deutschland GmbH

Stuttgart, Germany

Tel : +49 711 6868 7222

Marketing & Multimedia

Multi-D s.a.r.l

multi-d@ikkgroup.com

Multi-D

Beirut, Lebanon

Tel : +961 1 841 155

