

HOBART

**WAREWASHING
GLASSWASHERS GXC**



PROFI GXC



The perfect solution for high washing volumes but low installation height under the counter. Rack size 500 x 500 mm, compact installation height of 705 mm.

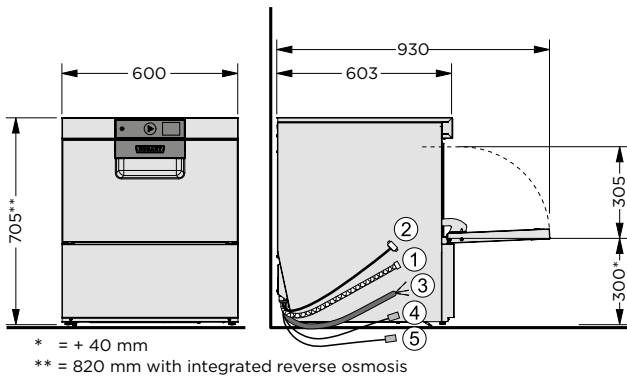

CONNECTIONS	
① Drain hose	2,000 mm ID20/OD25
② Supply hose	2,000 mm R 3/4"
Required flow rate	5 l/min
Flow pressure	0.5 (0.8 with softener) - 10 bar
Max. supply water temperature	60 °C
③ Power cord	2,000 mm
Supply hose for	
④ Detergent	2,500 mm
⑤ Rinse aid	2,500 mm

TECHNICAL DATA	
Cycle times*	60 / 90 / 120 sec. and special cycles
Water consumption	2 l/rack
Tank capacity	10.6 l
Tank heating	1.7 kW
Power supply	400 / 50 / 3N (230 / 50 / 1)

BOOSTER LOADING	
Standard	6.2 kW
Alternative	2.1 kW

TOTAL LOADING	
Standard	6.8 kW 3 x 16 A
Alternative	2.7 kW 16 A

Wash pump	0.5 kW 350 l/min
Rack size	500 x 500 mm
Loading height	305 mm
Noise level	60.5 dB (A)
Weight (gross / net)	70 / 60 kg

PRODUCT ADVANTAGES

- **Compact glasswasher:** with an installation height of only 705 mm ideal for narrow places or with integrated reverse osmosis and an installation height of 820 mm ideal for undercounter installation
- **VISIOTRONIC-TOUCH control:** colour touch screen (displays text and graphic) in conjunction with single-button control and remaining cycle time indication
- **WASHSMART app:** controlling your warewash operation with smart technology: status and messages, usage and operating costs, hygiene, service and consumables order
- **SENSO-ACTIVE resource management:** constantly measures the quality of the wash water and keeps the amount of rinsing needed in each rinse cycle to the minimum in order to guarantee a fully hygienic wash result
- **CLIP-IN wash and rinse arms:** wash and rinse arms can be removed with one hand and without any tools
- **Intelligent data documentation:** automatic recording of important operational data and consumptions and indication on the display
- **USB-interface:** comfortable download of operational data in form of a protocol via USB
- **GENIUS-X² fine filter system:** advanced filter system with pre-wash function reduces detergent consumption up to 35%
- **Intensive programme:** intensive rinse cycle to wash glasses with critical design with raised fresh-water amount
- **Interlocked strainer:** prevents operation without tank strainer
- **Optional refill signal:** monitors contents of external as well as integrated chemical containers
- **Hygiene programme:** for removal of calcium carbonate and other deposits from wash chamber

* Thermostat guarantees required temperatures with cold water and / or 230 V connection, the actual cycle times extend accordingly. For machine protection the water hardness should not exceed 3°dH, if higher we recommend using an integrated water softener or an external water softener of the product line HYDROLINE PROTECT. To avoid spots and streaks on the wash ware, we recommend the usage of a demineralisation cartridge (HYDROLINE STAR / STAR EXTRA) or a reverse osmosis system HYDROLINE PURE.